

美國新聞處影片目錄

美國新聞處

台北市南海路五十四號
台中市双十路一段二二一號

台南市府前路八十八號
高雄市中華三路一四一號

國立台灣大學圖書館



0919602



USIS FILMS

UNITED STATES INFORMATION SERVICE

54 NAN HAI ROAD, TAIPEI
121 SHUANG SHIH ROAD, SEC 1, TAICHUNG

88 FU CHIEN ROAD, TAINAN
141 CHUNG HWA 3rd. ROAD, KAOHSIUNG

013.52
8060

美國新聞處——隨時為你服務

美國新聞處在中華民國的工作目標，為增進中美兩國間的友誼與諒解，並促進兩國的共同進步。美國新聞處的職員隨時竭其所能，為你服務，以期盡量提供你所需要的資料與服務。多種不同的新聞及文化資料均可在臺北，臺中，臺南，高雄四地的美國新聞處，及嘉義，屏東，金門馬祖四處的閱覽室直接索得。

臺灣美國新聞處的組織概況如下：

新聞及出版組負責對各報館，雜誌社，政府機構及民間團體，發送各種新聞稿件及資料。該組亦編印各種雜誌及新聞畫刊，發送東南亞地區華僑及臺灣區讀者。
設在臺北市南海路五十四號的美國新聞處圖書館及林肯中心，有各種美國參考書籍及雜誌，並經常備各種唱片及室內音樂欣賞節目，照片展出，名人演講，特別展覽，及其他文化活動。本處文化組亦辦理各種美國政府主持的文化交換及書籍翻譯計劃。
廣播組製作國語，臺語，及英語節目以供臺灣各廣播電台播送本地聽眾，更供美國之音，遠東及東南亞各電台，播送給各地華僑聽眾。
電影組有本目錄所列的各種美國製紀實影片，供各學校，專業機構及民間團體借用。並有流動電影車兩部，經常在各鄉鎮作巡迴放映，電影組亦攝製各種紀實影片，向海內外報導臺灣的生活及進步。

919602

1950年10月
10月1日
10月1日

本處電視組有美國製電視影片，供臺灣各公私營電視台借用。其中有英語教學影片，一般新聞短片，及有關美國，太空，及世界其他地區重要新聞特輯影片。本處電視組亦供應有關中華民國的新聞片，及美國新聞總署發行全球有關中華民國的各項新聞報導影片。

本處電影組各種影片，除部份因數量有限，須在映期前預先借用外，大部份影片均可在規定借片時間內借到。任何機關團體如需本處未有的某影片，本處可向華威頓美國新聞總署，作特別申請。本處視此項工作為服務的一部份，願竭其所能，達成此類需求。惟詢獲此類影片，往往需時數月，有時甚至無法找到。

本目錄編印之目的，在使臺灣各機關團體及學校便於借用美國新聞處之影片。凡一九六七年三月一日以前之影片，均列入目錄。至以後新到之影片則增列入附錄。

如欲預約影片，亦可向就近之美國新聞處，先行辦理預約手續。

影片借用須知：

- 一、任何機關團體借用影片，須先填妥影片借用登記卡，該卡可逕向本處電影組索取。
- 二、初次借用影片，須由合格的放映人員，將放映機携來本處檢查。借用單位亦可派員來本處學習放映技術，本處樂於免費教授。借還時間臺北和臺中暫定星期一至星期五，下午一、三〇—五、〇
- 〇，遇假日則休息，臺南和高雄為上午八—十二時；下午一、三〇—五、三〇。
- 三、本處影片出借，概不收費，惟借用單位應負責影片完整無損。
- 四、本處影片均屬一六厘米，多為五彩片，大部份為英語或國語，亦有少數臺語。

- 五、附隨影片之放映報告單，借用單位應詳為填寫，俾供本處改進服務之參考。
- 六、借用影片時可事先多列數部影片，以便欲借之影片已借出或註消時，有所選替。

影片保護：

下列幾點影片保護法，有助於影片使用年限之延長因而增進對借用者之服務。

- 一、裝片前，須先清潔放映機，尤其影片接觸的轉動部份。因影片損壞，大多由於放映時受外物摩擦所致。
- 二、切勿用無聲電影機放映有聲影片，以免損壞聲帶。
- 三、裝上影片後，應先用手轉動少許，查視裝片有否不當，以免開動機器拉損影片。
- 四、放映時，機器如有異響發生，應即停止，並檢查推進齒，以免影片夾住或拉斷。
- 五、放映期間，放映人員不可離開放映機。如有斷片發生，應記住於還片時說明，以便修妥後再行出借。

分類目錄

四

農業
建築與工程
藝術與音樂
原子能
航空，太空，及飛彈
通信
水利
教育
漁業與林業
工業與勞工
國際關係
新聞
圖書館與博物館
軍事
職業
公共衛生與福利

人物
宗教
中華民國
科學
運動與娛樂
運輸
聯合國
美國
婦女
青年

下頁起所列係本室現有影片。片名上方的數字為影片號碼，片名下由虛線指出的數字是該片詳細說明所在的頁數。

五

農業類

B 〇〇七	農業，工業與電力	二六
C 七四二	美國農業	二六
D 八一七	美國農村	三五
B 四一三	農家好	四二
D 四〇〇	大地豐收	四三
B 四〇五	養豬	四四
A 一三一	蝗災	五〇
A 二三八	飼養家禽	五九
B 二三九	電化農村	五九
A 六一九	耕耘機	五九
A 六二七	鯉魚的人工繁殖	六一
B 五〇七	合歡橋	六一
A 六二〇	撲滅野鼠	六三
B 三一四	大豆	七四
A 三一八	鄉村與技術	七五

建築與工程

C 六三三	建設新世界	三二
B 八二九	建設未來	三二

藝術與音樂

D 八二七	美國的想像力	二八
C 六九六	美術寶藏	二九
C 五九〇	西方世界的藝術	二九
B 七二九	中國繪畫的藝術	二九
B 六二一	李湘芬的藝術	二九
C 二五三	魯賓斯坦（一〇一集）	三〇
C 二九三	托斯克尼尼	三〇
B 〇二三	亞洲藝術家繪飾玻璃品	三〇
A 五八〇	查理羅素之友	三三
A 六九一	中華文物	三三
C 〇六〇	美國農村的藝術	三四
C 〇六二	舞向自由	三四
B 〇六七	水彩畫家曾景文	三七
C 八二一	五時二分頌	三八

C 〇七六	林肯的面貌	三八
B 三八〇	天下一家	三九
A 一三四	壁畫的畫法	五一
C 一四一	歌星瑪麗安德遜女士	五二
B 四六六	電影的起源	五六
A 二二二	抽象畫法	五七
B 六六〇	印刷圖製作家	六〇
C 七三七	預演	六二
A 七七四	弦樂器製造學校	六三
A 二六〇	卷畫	六四
C 二七四	遍佈全國的交響樂	六七
C 二七五	空中交響樂團在日本	六八
C 七三五	交響樂之塔	六八
B 二七八	坦格瑪音樂學校	六八
B 七四一	三千年的中國藝術	七〇
C 七四〇	要使音樂飄揚	七七
C 八〇五	美國畫家	七九

原子能

B 〇〇七	農業，工業與電力	二六
C 三五七	原子能的功用	三一
B 三六〇	原子發電新試驗	三二
B 一一三	介紹原子	四七
B 六一〇	原子時代新生活	五〇
B 一四二	醫藥	五二
B 六一七	核子商船薩凡那號	五五
C 七六五	冰下之城	六六
B 三三五	同心協力	七八

航空、太空及飛彈

A 八〇二	環繞大地奔向月球	二六
A 〇六五	防空威力	三六
B 八一	訓練太空人	三六
C 六〇六	衛星探測太空	三八
A 六六二	太空十五日	三九
B 八一〇	雙子星四號	三九
C 七一一	友誼七號	四一

A 七〇三	葛倫飛繞地球	四八
B 八三二	太空聚會	五二
B 八〇四	太陽神計劃	六一
B 七六三	電視轉播衛星	六一
A 七八三	神農號太空艙	六三
B 六四九	星際航空概況	六七
A 八〇七	太空漫步	七五
A 六二八	太空實驗	七八
C 六五〇	X—十五號	七九

通信

B 七三二	歐美相通	二七
B 五九六	體小力偉	五〇
B 七六三	電視轉播衛星	六一
A 二五一	鄉村郵政	六三

水利

B 四二六	灌溉農田	四七
B 五〇七	合歡橋	六二

C 六四八	聖勞倫斯動力計劃	六三
C 三〇〇	田納西大壩	六九

教育

C 七三〇	美國實地服務團故事	二七
C 六七四	學術中心	三二
C 〇六四	暗程	三五
B 〇六八	改善生活的教育	三七
C 六九九	學業收獲	四三
B 八二〇	學習謀生之道	四九
C 四五八	並非偶然	五五
A 七七四	弦樂器製造學校	六三
C 二六四	基本三課	六五
A 七七六	半工半讀的學生	六七
B 二七八	坦格烏音樂學校	六八
A 七七三	珍視我們的土地	七〇
B 六九七	學術之塔	七三
B 二九六	原子時代的人才訓練	七三

A 三一七 鄉村與學校..... 七五
 B 六〇八 前途..... 七六

漁業與林業

B 三九四 翡翠寶島..... 四二
 B 六二二 人與船..... 五三
 B 六八八 虱目魚的繁殖..... 五三
 D 二六三 捕蝦人..... 六五

工業與勞工

C 〇〇八 一個美國工廠..... 二七
 C 五七八 谷外天地..... 三一
 C 六一四 世界市場的重大變動..... 三一
 B 八二九 建設未來..... 三二
 B 三七四 鴨毛..... 三七
 B 八二三 四要素..... 四〇
 B 四〇八 益壽延年..... 四五
 B 一三五 金堅玉潤..... 五一

B 五七二 汽車城風光..... 五八
 B 六六一 開發的成就..... 六一
 C 五二八 為前途投資..... 六四
 C 三四八 自動化工業..... 七〇
 B 二九〇 開更大眼界..... 七二
 B 三一四 大豆..... 七四
 B 七八一 紐約世界博覽會..... 七八

國際關係

C 五七八 谷外天地..... 三一
 C 八一八 友信的橋樑..... 三二
 B 八五七 越南邊區的建設..... 三六
 B 五九二 世上珍寶..... 三七
 A 〇八三 臺灣的進展..... 四〇
 B 五九九 友誼的聯繫..... 四一
 A 八四五 外來的援助..... 四三
 D 一〇一 喜馬拉雅的覺醒..... 四四
 B 七三一 有希望之島..... 四八

B 四三三 重見天日.....五〇

A 一三一 蝗災.....五〇

C 八一三 恐怖之夜.....五五

B 八二八 一枝小蠟燭.....五六

B 八四九 越南鄉村重建工作.....五六

C 四九四 石油與人類.....五七

B 二三一 菲律賓的進步.....五八

D 六六一 開發的成就.....六一

C 二五二 百日路.....六二

B 八〇一 進步的盾牌.....六五

B 六七七 東南亞公約衛護自由.....六六

B 六五九 甘迺迪總統在歐洲.....六八

A 六七一 休戚相關.....六九

B 二八二 無須枉死.....七〇

B 二八三 菲律賓報導.....七〇

B 五四二 馬尼刺之行.....七一

C 八二五 前程在握.....七二

B 二九六 原子時代的人才訓練.....七三

B 七八〇 勞苦的收穫.....七三

A 六二九 憂患之島.....七四

新聞

C 〇二五 服務人群.....三一

B 〇五八 小城報館編輯.....三四

B 八〇三 總統與記者.....六〇

A 六二九 憂患之島.....七四

圖書館與博物館

C 五九五 服務大眾的公共圖書館.....三一

B 〇九五 無上的寶藏.....四二

C 四一六 可教之年.....四六

B 二七〇 美國國史館.....六六

B 三三一 美國自然科學博物館.....七八

軍事

C 五八一 雷達警報網.....三六

B 七八九 同舟共濟.....四六
 A 一五三 鸚鵡螺號航經世界極點.....五四
 C 八一三 恐怖之夜.....五五
 A 七八六 武力實況.....六〇
 B 六七七 東南亞公約衛護自由.....六六
 B 七八二 保持和平.....七十二

職業

B 五九四 訂書工人.....二七
 B 六〇一 玻璃工人.....二八
 B 六一二 陶瓷工人.....二八
 A 七七五 青年木工.....四六
 C 四五八 並非偶然.....五五
 A 七七六 半工半讀的學生.....六七

人物

C 〇一二 牧童米格.....二八
 A 五八〇 查理羅素之友.....三三

B 八〇八 美國總統宣誓就職大典.....三五
 C 七七九 可靠的掌握.....三六
 B 一二七 美國總統艾森豪傳.....三八
 C 〇七六 林肯的面貌.....三八
 B 八一二 林肯的同鄉——史蒂文生.....四一
 C 二七七 海倫凱勒故事.....四四
 A 六八二 危急之秋.....四四
 C 七三八 葛倫的故事.....四八
 B 八二二 重大旅行.....四八
 B 六八四 第福瑞斯特小傳.....五二
 B 六七八 致力和平.....五七
 B 七六八 詹森總統.....五九
 B 六五九 甘迺迪總統在歐洲.....六八
 C 六一三 培植未來.....七二
 C 三二八 威爾森——明日的發言人.....七八
 D 三三九 湯川執事.....七九

公共衛生與福利

A 三六五	清水	三三
A 三六六	持潔不病	三三
C 〇六四	暗程	三五
B 三七一	防禦侵犯	三五
A 七〇八	海中取淡水	四一
B 四一四	無病就是福	四三
A 四〇七	十二指腸蟲	四四
B 四〇八	益壽延年	四五
A 四〇九	疾病怎樣傳染	四五
A 四一一	人體	四五
A 四一八	育嬰法	四七
A 四二〇	昆蟲傳染疾病	四七
B 一三六	清除瘧疾	五一
B 一三八	醫學的發展	五一
B 四四八	人造富源	五一
B 一四二	醫藥	五二
A 八一五	為民服務的人們	五三
B 一五九	紐約市水源	五五

D 四八九	公共衛生護士	六一
A 五〇二	盲人再生	六二
A 六六五	廚房洗槽的作法	六五
A 六六四	怎樣節省燃料及粉刷房屋	六七
A 五三九	肺癆病	七三
A 五五四	水，汝之友；汝之敵	七五
A 五六一	可怕的瘧疾蚊	七七
C 六七二	手與心	七七

宗教

B 八二二	重大旅行	四八
-------	------	----

中華民國

A 〇八三	臺灣的進展	四〇
B 三九四	翡翠寶島	四二
B 四三〇	金門農家樂	四九
B 四三一	耕者有其田	四九
C 七〇四	我加入了四健會	五〇

B 五〇七	合歡橋	六二
C 八三三	自由的力量	六五
B 七一四	李麗珠的故事	六七
B 五四七	金門	七〇
B 七四一	三千年的中國藝術	七〇
A 六八九	雷虎小組訪越	七一
B 五五八	當共黨來後	七六
B 六四三	快樂家庭	七八

科學

B 五八六	南極洲	二九
C 五九八	海岸防衛隊巡邏船環繞北美一週	三四
B 八一	訓練太空人	三六
C 六〇六	衛星探測太空	三八
B 八二三	四要素	四〇
A 七〇八	海中取淡水	四一
A 四一一	人體	四五
B 一一三	介紹原子	四七

B 五九六	體小力偉	五〇
B 一四二	醫藥	五二
A 一五三	鸚鵡螺號航經世界極點	五四
B 七一五	食物與營養	五六
B 四六六	電影的起源	五六
B 六九二	探發太平洋	五七
C 二三〇	古河化岩	五八
C 七六六	南極電源	五九
B 四八七	電學原理	六〇
B 五二五	科學的進展	六三
C 七六五	冰下之城	六六
B 六四九	空星際航概況	六七
C 七〇〇	第十屆太平洋科學會議	六九
C 三四八	自動化工業	七〇
B 二八六	時計之發展史	七一
B 二九〇	開更大眼界	七二
B 三一四	大豆	七四

運動與娛樂

C 〇二四 二屆亞洲運動會.....三〇

B 〇八四 無限江山.....四〇

A 五〇八 海獅棒球隊.....六四

A 五一一 軟式棒球術.....六六

A 〇九一 網球冠軍.....六九

C 五五五 獵犬訓練法.....七六

A 六五五 威瑪盧道夫，奧林匹克錦標選手.....七七

B 三三七 國立黃石公園.....七九

運輸

A 一五三 鸚鵡螺號航經世界極點.....五四

聯合國

A 六八二 危急之秋.....四四

B 六七八 致力和平.....五七

美國

B 二七六 阿拉斯加—美國的第四十九州.....二六

B 五七三 阿拉斯加—美國最新一州.....二六

D 六一一 紐約全貌.....二六

C 六一四 世界市場的重大變動.....三一

C 〇五一 橫跨大陸.....三四

B 八〇八 美國總統宣誓就職大典.....三五

C 六九〇 美國遊記.....三九

C 七二〇 邊疆.....四二

B 六〇七 夏威夷.....四三

C 六四四 同室操戈.....四五

B 六四五 甘迺迪就職大典.....四六

A 八〇六 美國國慶日.....四六

C 四三八 法律的產生.....四九

C 六八三 國家之興起.....五三

C 一五一 策定方針.....五四

C 一五七 新大陸.....五四

B 二二九 西海岸的人民.....五七

C 二三四 自由之土.....五八

B 七六八 詹森總統.....五九

A 二四四	小鎮的問題.....	六〇
A 二五一	鄉村郵政.....	六三
B 二六九	各州與全國.....	六六
C 二八九	爭取自由.....	七一
C 二九二	鞋匠政治家.....	七二
B 三〇五	今日美國.....	七四
D 三〇七	美國.....	七四
A 七八八	我們必須克服.....	七六
C 三二二	華府觀光.....	七六

婦女

C 一四一	歌星瑪麗安德遜女士.....	五二
A 〇九一	網球冠軍.....	六九

青年

C 七三〇	美國實地服務團故事.....	二七
C 六八〇	堪當大任.....	五三
B 四六一	青年旅行會.....	五六

C 六八一	童子軍的道路.....	六四
-------	-------------	----

A 八〇二

環繞大地奔向月球

英語，國語，黑白片，一〇分鐘。

本片報導太空人葛理森及楊格太空飛行的重要事項及遊騎兵九號的月球發射。

B 〇〇七

農業、工業與電力

英語，國語，黑白片，二〇分鐘

報導在農業、工業生產、動力發展等方面使用放射性物質之研究；說明現在所已獲致的一些明顯的成就，而著重於原子能之使用於提高各國的經濟水準。

C 七四二

美國農業

英語，國語，五彩片，三〇分鐘

敘述美國的農業，如何由早期私人農場有限度的生產轉變而為今日大量生產的奇蹟。

B 二七六

阿拉斯加：美國的第四十九州

英語，國語，五彩片，二〇分鐘

介紹阿拉斯加美麗的風景、城、鎮、工業及人民的生活情形。

B 五七三

阿拉斯加：美國最新的一州

英語，國語，黑白片，二〇分鐘

美國前總統艾森豪簽署阿拉斯加建州的法案。本片介紹有關阿拉斯加的一般知識和背景資料及其潛力。

D 六一一

紐約全貌



B 七三二

歐美相通

英語，國語，疊語，黑白片，一五分鐘

介紹紐約州，紐約州的人民、農業、工業、文化及名勝古蹟。

C 〇〇八

一個美國工廠

英語，國語，黑白片，二五分鐘

本片在美國奇異電氣工廠攝製介紹該廠自動製造冰箱設備及一般美國工業之概念。

C 七三〇

美國實地服務團故事

英語，國語，五彩片，三〇分鐘。

介紹美國實地服務團的國際獎學金計劃，描述一位薩丁尼亞少年在美國的經驗和一位美國少女在薩丁尼亞的經驗。

B 五九四

訂書工人

英語，國語，黑白片，一三分鐘

敘述自裁割、摺疊、以至縫、壓訂和加裝封面而製成書籍的過程。裝訂的書籍包括小冊子、格子筆記簿、帳簿，以及會計表格和紀錄簿。片中特別有興趣的部份是需要極大耐心和細心的書籍修補工作。

B 六〇一 玻璃工人

英語，國語，黑白片，一三分鐘

在大量生產下現代製造玻璃的各項步驟，從原料的混合以至製成品的自動包裝均加詳細說明。本片顯示在具有現代設備的現代工廠中，工人吹玻璃，塑型，花飾，最後的整理及檢查等情形。施色或塗塑膠，製玻璃管和纖維玻璃及用機器檢查和包裝等的技術表明吹玻璃工人的行業所使用的技術需要的高度技巧和智能。

B 六一二

陶瓷工人

英語，黑白片，一三分鐘

本片為美國勞工聯合會及工業組織聯盟所拍製，介紹美國陶瓷工業大量生產的情形及熱練的工人及藝術家介身於此項三十億資本工業的概況。着重於陶瓷工業在美國自由企業體系中所佔地位及陶瓷工藝與其他有關工業的相依情形。

D 八二七

美國的想像力

英語，國語，五彩片，四〇分鐘

本片按年代順序介紹十九世紀末期至廿世紀初期美國藝術家之繪畫作品。

C 〇一二

牧童米格

國語，臺語，黑白片，六〇分鐘

本片介紹新墨西哥州北部某牧羊場中之家庭傳統習慣，及敘述孩童志願成為牧人，及其如何學習負責任尊重傳統，乃至其因能自力工作而自豪。本片亦略述牧羊場之方法。

B 五八六

南極州

英語，國語，臺語，黑白片，二〇分鐘

紀錄各國在南極探險勘察工作的成績，包括國際地球物理學年的成就。紀錄片中的插圖取材於初期的報紙，描述美國及其他國家在南極探險方面的貢獻。

C 六九六

美術寶藏

英語，國語，五彩片，三〇分鐘。

介紹紐約市大都會藝術博物館的藝術品。這些象徵人類歷代創作生活，是一種文化遺產，提供過去文化的知識及對人類發展的影響。該博物館所主辦的各項文化活動也有說明。

C 五九〇

西方世界的藝術

英語，國語，五彩片，三〇分鐘

介紹美國國家藝術館所珍藏的每一主要時代的藝術品，自東羅馬帝國的比尚興以迄於今，說明西方藝術的發展情形。

B 七二九

中國繪畫的藝術

英語，國語，臺語，五彩片，二〇分鐘

介紹畫家黃君璧，以中國藝術家的傳統方式作畫。

B 六二一

李湘芬的藝術

英語，國語，五彩片，一七分鐘

李湘芬不是一位普通的女藝人。她的戲完全是中國正統的平劇藝術。她在大陸上開始

學戲，是梅蘭芳的高足。因為她所愛好的藝術受到壓制，不能發展，所以她逃出大陸。本卷電影是李湘芬自己選的三部戲：「紅線盜盒」，「貴妃醉酒」，「天女散花」。

C 二五三 魯賓斯坦（第一〇一集）

英語，國語，黑白片，二五分鐘

敘述魯賓斯坦在其家中及錄音室中練習之鋼琴獨奏曲，計有孟德爾生之『紡織歌』，李斯特之『愛之夢』，蕭邦之『升C調華爾滋舞曲』，及蕭邦之『A調波蘭舞曲』。

C 二九三 托斯克尼尼

英語，國語，黑白片，三〇分鐘

托斯克尼尼指揮國家廣播公司交響樂團，皮爾斯獨唱，西敏唱詩班合唱，特別演出以慶祝意大利法西斯壓迫下獲得解救。演出的節目有威爾第的『命運之力』的序曲和「民族讚美詩」。

B 〇二三 亞洲藝術家繪飾玻璃品

英語，國語，臺語，黑白片，二〇分鐘

本片是在華府國立藝術館，紐約大都會美術博物館所攝斯杜本玻璃公司的一九五六年展覽會情形。展覽品包括三十六件美國的精製玻璃品。這些玻璃品的雕刻是取材十六位亞洲和中東國家當代第一流藝術家的繪畫。圖畫中敘述民間傳說。宗教傳統和地方的風土人情等。

C 〇二四 二屆亞洲運動會

英語，國語，黑白片，三〇分鐘

一九五四年五月在馬尼拉舉行的二屆亞洲運動會的實況報導，從本片可以看到亞洲各國選手們的比賽鏡頭。

C 〇二五 服務人羣

英語，國語，五彩片，二八分鐘

介紹發行一個國際性日報的複雜而艱巨的工作，激勵（基督教科學箴言報）的理想，以及負責經營該報的人物。除顯示該報在波士頓各部門的工作情形外，並介紹該報派駐世界各地的記者工作情形。

C 五七八 谷外天地

英語，國語，五彩片，三〇分鐘

波多黎各在外國私人投資及政府合作之下工業發展概況。

C 六一四 世界市場的重大變動

英語，國語，伊士曼彩色片，三〇分鐘

自由世界戰後經濟進步的情形，重點置於生產力和一般工人家庭購買力的增加。包括各業活動：工業、農業、運輸、礦業、衛生、教育、住宅、銷售等。

A 三五七 原子能的功用

英語，國語，黑白片，一〇分鐘

本片為日本人在原子能研究方面之成果概況，及日本科學家和技術人員的成就。

C 五九五 服務大眾的公共圖書館

英語，國語，五彩片，三〇分鐘

敘述一所小鎮公共圖書館在社會中所負的任務。

B 三六〇 原子發電新試驗

國語，黑白片，二〇分鐘

原子研究的實驗。敘述初步的實驗工作及一座沸水動力反應器的建造和使用情形。實際的成績可從一所實驗發電廠使用核子動力發電以供應愛達荷州阿柯市的電力表明。

C 八一八 友信的橋樑

英語，國語，五彩片，二五分鐘

本片為韓國總統朴正熙訪問美國之記錄片，在其訪美期間，朴總統曾參觀紐約市，並蒞臨世界博覽會『韓國之日』，他曾參觀西點軍校，並至甘迺角觀摩太空艙發射情形。

C 六三三 建設新世界

英語，國語，黑白片，三〇分鐘

本片介紹美國自第一批移民至目前之建築發展情形，由其建築之演變可看出美國之歷史背景。

B 八二九 建設未來

英語，國語，五彩片，二一分鐘

本片描述建築工業在其工兵，技術，及管理方面之成長，改進與步向現代化之情形。

C 六七四 學術中心

英語，國語，五彩片，三〇分鐘

介紹六所學術中心，這是美國各種型式大學的代表：固有的傳統是個人選擇其學校和職業的自由，大學的自由設立和教學的自由。

A 五八〇 查理羅素之友

英語，國語，五彩片，一〇分鐘

透過聞名國際的美國牧童藝術家的作品而描繪出其所熟悉喜愛之西部人民。

A 六九一 中華文物

英語，國語，五彩片，一〇鐘

目前保藏於臺灣的中國故宮藝術珍品展覽。

A 三六五 清水

國語，五彩片，一〇分鐘

天然水道的重要；染污的水對於魚類，鳥獸，對於城市供應系統，娛樂設施及公共衛生的危險性。本片是和美國公共衛生處合作攝製。

A 三六六 持潔不病

國語，五彩片，九分鐘

一個幸福健康的家庭中衛生和個人清潔情形，與一個患病疏忽的家庭中的情形互作對照。說明簡易的衛生措施和個人保健如何使一家人保持健康，在其他家庭中，疏忽的習慣如何引起疾病。

C 五九八

海岸防衛隊巡邏船環繞北美一週
英語，國語，五彩片，三〇分鐘

美國海岸防衛隊三艘巡邏艇作一次歷史性航行，首創在水面上通過北美洲北極區的一次自西海岸至東海岸的航行。

C 〇五一

橫跨大陸

英語，國語，黑白片，三〇分鐘

美國開拓的初期歷史和移民西部有關。當東部城市在文化上和商務上都已發展之際，有大批的拓荒者不憚跋涉深入西方荒野之地。本片概述西北地區及路易斯安那州購買後移民的若干區域的情形：邊區生活對於美國國民特性之發展的影響。

B 〇五八

小城報館編輯

國語，黑白片，二〇分鐘

本片敘述小鎮編輯的日常生活。本片着重於在新聞自由之下，公正及為大眾服務的傳統精神；並支持言論自由的原則。

C 〇六〇

美國農村的藝術

國語，黑白片，三〇分鐘

美國威斯康星州鄉間的工人，農民和農婦們的藝術；研究中心的藝術評論；各種藝術作品的展覽會。

C 〇六二

舞向自由

C 〇六四

暗程

英語，國語，黑白片，三〇分鐘

敘述匈牙利芭蕾舞家從西柏林逃奔自由經過，特別對事先的計劃及脫逃的步驟有詳細說明。

B 八〇八

美國總統宣誓就職大典

英語，國語，五彩片，二〇分鐘

一個最近失明的青年在身體及心理上適應盲人生活的情形。他在盲人監護學校獲得了情緒上的穩定，社交的能力，及如常人般適應各種要求的能力。

D 八一七

美國農村

英語，國語，五彩片，四〇分鐘

介紹經營三〇〇英畝農場為一成功的家庭企業，應用科學方法，其產品不但使六口之家自足，且可供應市場，現代科學耕具及方法輔助生產，節省時間農業機械之大量應用，長期計劃及有效管理，區域性組織的農場合作可提供農民個人及社區的各種需求。

B 三七一

防禦侵犯

國語，五彩片，一三分鐘

以動人的譬喻解釋免疫的價值；以敵軍入侵為例；免疫猶如防衛。

A 〇六五

防空威力

英語，國語，臺語，黑白片，一〇分鐘

美國飛彈的研究和發展——報告美國目前對科學的進步及自由世界的安全所作的貢獻。敘述各種飛彈的發射情況及該項飛彈的潛能和實際成就。

C 七七九

可靠的掌握

英語，國語，五彩片，二八分鐘

介紹在不同地區四個美國飛行人員的家庭成長與發展，四個飛行人員分別為機長，機械師，駕駛員及空中小姐。

B 八一

訓練太空人

英語，國語，五彩片，一八分鐘

報導美國最近在太空醫學方面研究的結果。

C 五八一

雷達警報網

英語，國語，五彩片，二七分鐘

本片介紹設置於北極圈的雷達警報網之計劃及架設情形。

B 八五七

越南邊區的建設

英語，國語，黑白片，一五分鐘

本片敘述一個美國國際開發總署的代表，在越南一個偏僻的省份每日工作的情形，他和該省的省長，地方警察首長以及美國軍方人員一起工作，幫助居民得到食物，住所和安
全保障。

B 〇六七

水彩畫家曾景文

英語，國語，五彩片，二〇分鐘

藝術家曾景文在紐約華埠臨摹街頭景色，先畫草圖，然後在家中完成其畫。並介紹這位畫家的寓所情景。展示其受到現代和東方影響的作品多幀。本片着重於曾君之成就及其對美國文化生活之貢獻。

B 三七四

鴨毛

英語，國語，臺語，黑白片，一八分鐘

本片介紹一越南家庭得政府援助從事羽毛生產。

B 五九二

世上珍寶

英語，國語，黑白片，二〇分鐘

報導國際青年商會第十三屆世界年會在明尼蘇達州的明尼普利斯開會的情形。

B 〇六八

改善生活的教育

英語，國語，臺語，黑白片，二〇分鐘

菲律賓政府為促進學校和社會間的密切關係而實施的試驗性計劃。菲律賓在本嘉辛南的巴葉姆本地方設立的社區教育訓練中心。顯示來自聯合國文教組織的技術援助；該中心

的指導委員會；十星期的訓練課程。

B 一二七 美國總統艾森豪傳

國語，臺語，黑白片，二〇分鐘

這是一部傳記影片；紀錄艾森豪總統的童年，學生時代及在西點軍校時的情形；其在美國軍中的事業，以第二次世界大戰期間統率歐洲盟軍，為其輝煌服務的頂點；受任美國陸軍參謀長；哥倫比亞大學校長；北大西洋公約組織最高盟軍統帥；當選及就任美國總統。

C 八二一 五時二分頌

英語，國語，五彩片，二六分鐘

本片用電影表示人類在這瞬息萬變的世界如何享用自由，讓人們追頌這被遺忘的一分鐘自由，當倫敦英國議會鐘樓之鐘指着五點零二分時，有二十個無始無終，亦無歷史價值的故鄉在二十個城市同時發生，一個在印度的結婚典禮，一個柏林的蠟筆畫家，一個倫敦的少女舞廳，南美洲的農收，日內瓦的觀光客，美國的一個小孩的誕生，以及拉丁美洲的一個遊樂公園都在一七六五年五月十八日五時零二分發生。

C 六〇六 衛星探測太空

英語，國語，五彩片，三〇分鐘

介紹人造衛星的結構和儀器，以及各項儀器的用途及目的。

C 〇七六 林肯的面貌

英語，國語，臺語，黑白片，三〇分鐘

美國名雕刻家蓋琪重新塑造林肯的面部雕像，同時他敘述林肯的生平事蹟並顯示林肯在遭遇各種事件時，西部反映的表情。

B 三八〇 天下一家

英語，國語，臺語，黑白片，二〇分鐘

美京華威頓之哥克倫美術館所舉辦之「人類生活方式」照片展覽會，皆拍攝於此片中，而以若干介紹式鏡頭，推薦人類日常生活方式之作品。美國攝影界權威史泰塵氏解述各展覽作品之意義以及利用攝影為藝術之媒介，而各作品及其標題亦能充分表達該展覽會之宗旨，即全球之聯繫與人類之美德。

A 六六二 太空十五日

英語，國語，黑白片，一〇分鐘

美國的太空發展，包括泰羅斯及邁達斯衛星的進入軌道，美國空軍格里森上尉一九六一年七月二十一日的首次軌道太空飛行。

B 八一〇 雙子星四號

英語，國語，五彩片，一二分鐘

報導太空人麥迪維特與懷特於一九六五年六月三日環繞地球六十二圈的飛行實況，詹森總統的歡迎太空人及其家屬的盛況，太空人懷特的二十分鐘『太空漫步』及其與麥迪維特的空中通話，均在片中報導。

C 六九〇 美國遊記

英語，國語，五彩片，三〇分鐘

A 三八五 美國的新聞記者眼中的美國：美國的工業，農業，水土保持，天然資源及人民。
美國的外國運動

國語，黑白片，一〇分鐘

A 〇八三 臺灣的進展
美國今日各種體育運動的淵源。起源的國家；多年來演變改進的發展情形。

國語，臺語，黑白片，一〇分鐘

報導美國與中國政府間關係的展望，臺灣的民衆目證並參加合作的計劃使這島嶼更安
全及發展至能自給自足的目標。

B 八二三 四要素

英語，國語，五彩片，一二分鐘

本片敘述把傳統所謂的空氣，水，火，土四要素組合轉變為製造品以說明美國的生產
能量，由本片可以看出，內華達州水壩及發電廠把水能變為電力；維基尼亞的自動煤礦；
賓夕法尼亞的碾米廠，德克薩斯州的油田及加利福尼亞州的煉油廠等的焦炭及鍊鋼爐。本
片更介紹各種原料經組合後製成纖維絲，再紡織為布疋，本片重點在說明人類生活的幸福
安適程度全視其能否善為利用空氣，水，火，土之天然富源而定。

B 〇八四 無限江山

英語，國語，黑白片，二〇分鐘

A 七〇八 海中取淡水

英語，國語，黑白片，一〇分鐘

美國境內各國立公園的景象，便利旅客及觀光度假者的各項設施。

英語，國語，黑白片，一〇分鐘

美國政府從海水中取淡水的計劃。將海水變為淡水的兩種方法。甘迺迪總統向世界保
證，這種科學知識將供給世界各國的科學家。

B 五九九 友誼的聯繫

英語，國語，黑白片，二〇分鐘

一個美國家庭和一個泰國家庭互相交換他們十八歲的兒子教養一年。介紹這兩個孩子
各自在異國環境中的生活和活動。

C 七一八 友誼七號

英語，國語，五彩片，五七分鐘

美國太空艙『友誼七號』，在太空飛行員海軍陸戰隊格倫的駕駛下，射入太空軌道的
經過情形。本片敘述整個計劃，包括信使神計劃地面駕駛員的協助，信使神控制中心發號
施令，以及分佈在三大洲的十八個追蹤測錄站的工作。最後，格倫安全降落大西洋，登上
驅逐艦『諾亞號』圓滿結束征服太空。

B 八一二 林肯的同鄉，史蒂文生

英語，國語，黑白片，一八分鐘

本片為紀念美國駐聯合國代表史蒂文生大使而作，片中追述其生平致力於世界和平

與正義的成就，他的一九五三年及一九五六年被選為民主黨總統候選人，一九四九年被選為伊利諾州州長，及一九六一年被任命為駐聯合國大使，這些都顯示出美國人民對他的擁戴，本片結尾為人們對這位人道主義者，公僕，作家及解放者在國會大廈及華盛頓天主教堂最後瞻仰的鏡頭。

C 七二〇

邊疆

英語，國語，五彩片，三〇分鐘

以猶他州和愛達荷州為代表的美國西部情形。本片包括該區域的歷史，地理，工業，文化，運動及人民等方面的記述。

B 〇九五

無上的寶藏

英語，國語，黑白片，二〇分鐘

美國國會圖書館成立的經過並介紹其藏書的規模。

B 三九四

翡翠寶島

英語，臺語，黑白片，二〇分鐘

介紹森林的適當管理和採伐之重要性，再造林及森林對於國家經濟的價值。本片並對發展臺灣的『綠化寶島』計劃作簡要的報導。

C 四一三

農家好

台語，黑白片，六〇分鐘

本片以戲劇性故事提供有關化學肥料實際使用方法的，頗有價值的資料及有益的農業

知識。

D 四〇〇

大地豐收

國語，台語，黑白片，四〇分鐘

化學肥料的生產和適當應用於各種農作物，造成農產品的豐收。

C 六九九

學業收獲

英語，國語，黑白片，三〇分鐘

美國政府撥地興建大專學校的歷史——這些大專學校的獨特性質及其對美國教育制度的貢獻。

B 六〇七

夏威夷

英語，國語，五彩片，二〇分鐘

本片敘述夏威夷的一般情況，其人民及資源。

A 八四五

外來的援助

英語，國語，黑白片，一〇分鐘

本片報導越南人民在美國及其他國家社會與經濟援助下，醫療傷患并為未來的和平根基進行建設的情形，本片更特為描述自由國家對越南的醫藥援助。

B 四一四

無病就是福

國語，臺語，黑白片，二〇分鐘

敘述環境衛生措施之重要；祇須遵守若干簡單規則即可使全家健康快樂。

C 二七七

海倫凱勒故事

英語，國語，臺語，黑白片，五〇分鐘

本片為海倫凱勒女士的傳記片，由凱勒女士演出，康乃爾女士配音，片中敘述凱勒自嬰孩至七十五歲生日的各重要事項，包括她訪問外國及與當時顯要們相會的新聞照片。

D 一〇一

喜馬拉雅的覺醒

英語，國語，臺語，五彩片，四〇分鐘

二十世紀的尼泊爾——其文化、社會和政治背景及其目前在印度和美國援助下獲致的經濟進步和開發計劃。

B 四〇五

養豬

臺語，黑白片，四〇分鐘

報導臺灣的養豬事業在農復會輔導下發展的詳細情形。本片強調豬羣傳染病的預防。

A 四〇七

十二指腸蟲

國語，五彩片，一一分鐘

不小心的查利患着嚴重的十二指腸病，不能下田耕作。當別人告訴他鈎蟲如何在污泥中繁殖滋生，它們如何寄生人體內，它們如何可以容易地加以撲滅時，查利就變得小心謹慎了。本片是卡通片。

B 六八二

危急之秋

英語，國語，黑白片，一〇鐘

C 六四四

同室操戈

甘迺迪總統於九月二十五日在聯合國大會發表演說的要點，他在這篇演說中要求蘇俄作和平的競賽——而不要作武器的競賽。

英語，國語，黑白片，三〇分鐘

由美國電影業供應的影片，當代的油畫和版畫及原始的照片，說明了一些成為美國立國基礎的自由概念。本片並簡略地說明美國在地理上的擴展及經濟成長的情形，最後並解釋使南方和北方陷於分裂而發生內戰的影響力量。

B 四〇八

國語，黑白片，二〇分鐘

一家美國大藥廠的製藥情形。

A 四〇九

疾病怎樣傳染

國語，五彩片，一二分鐘

本片說明污水接觸病人及帶菌昆蟲如何傳染疾病，採取衛生措施，病人，及其他簡易的預防措施，可以阻止病源。

A 四一一

人體

國語，五彩片，九分鐘

對於人體所非常簡單的研究：骨骼的結構，肌肉，呼吸，血液，腦。說明均衡的飲食，新鮮的空氣，整潔等對保持身體健康的重要性。

A 七七五 青年木工

英語，國語，黑白片，一〇分鐘

四六

C 四一六 可教之年

英語，國語，黑白片，四〇分鐘

一位青年木工選擇職業的經驗。

民主國家如何為健全的智力發展及灌輸學術的自由而努力；背景是紐約公共圖書館的兒童部。關於一個小女孩發現許多書的故事。本片含有輕鬆的幽默感，優美的攝影和獨創的新穎樂譜。

B 七八九 同舟共濟

英語，國語，五彩片，一八分鐘

本片報導美國軍艦勒凱茲號由不同國籍的船員聯合操作以證明此種混合工作之可能性，北大西洋公約國家參加者有美國、英國、意大利、德國、荷蘭、希臘及土耳其。

B 六四五 甘迺迪就職大典

英語，國語，五彩片，二〇分鐘

本片報導甘迺迪總統就職實況，在白宫與前任總統會面，由白宫至國會大廈及宣誓儀式，就職演說摘要，就職大遊行及當晚之各種宴會及舞會。

A 八〇六 美國國慶日

英語，國語，五彩片，一〇分鐘

敘述美國人民以各種方式慶祝七月四日他們的國慶日，以祝賀他們人權的民族理想和負責獨立宣言的英雄。

A 四一八 育嬰法

英語，國語，五彩片，一〇分鐘

明智的母親遵守着正當的規定飲食，照顧着自己和嬰孩，在嬰孩開始吃食固體食物後作適當的餵食。她經常作產前檢查，有助於使胎兒強壯和健康。

A 四二〇 昆蟲傳染疾病

國語，五彩片，一〇分鐘

不注意衛生的查利，與蒼蠅、蟲子、和蚊蟲住在一起，他在獲悉這些昆蟲怎樣是百病之源後，他成為一位注意衛生的查利。本片敘述他所應用的撲滅這些害蟲的方法。

B 一一三 介紹原子

英語，國語，臺語，黑白片，二〇分鐘

對原子和原子能作一基本解釋。然後次第說明原子的組成、功能、構造和可控制鏈鎖反應。並介紹洛塞勒摩斯原子彈實驗室內的原子堆。橡樹嶺原子能研究中心的準確和貯藏放射同位素。強調原子物質在醫學研究、農業和工業方面的用途。影片的最後部是艾森豪總統在聯合國發表的演說摘錄，這篇演說鄭重表示，美國希望和願意達成國際控制原子能，對世界各地的人類福利，提出貢獻。

B 四二六 灌溉農田

英語，國語，黑白片，二〇分鐘

本片敘述水渠灌溉和引水方法，以及波爾特水壩把天然資源的水用於灌溉上所負的任務。

B 七三一

有希望之島

英語，國語，五彩片，一五分鐘。

敘述波多黎各，藉長期性的計劃和政府及工業界協助訓練人民新式技術，走向現代化。

A 七〇三

葛倫飛繞地球

英語，國語，臺語，黑白片，一〇分鐘

這部動人的影片介紹葛倫駕駛著名的信使神太空艙『友誼七號』飛繞地球三週時，每一分鐘的高潮。本片並介紹在甘迺迪角發射前的準備情形，世界各地收聽站的地面支持，以及葛倫和他的太空艙在海上被尋回時的情景。

C 七三八

葛倫的故事

英語，國語，五彩片，三〇分鐘

本片是葛倫自童年到現在的傳記素描，包括他的學校和街鄰生活。

這部葛倫上校的傳記片，除了敘述他在太空方面的成就以外，並描寫他在中西部一個小地方的童年生活。

B 八二二

重大旅行

英語，國語，五彩片，一三三分鐘

教宗保羅六世於一九六五年十月四日訪問美國及在聯合國發表演說呼籲和平的實況紀錄。

B 四三〇

金門農家樂

國語，臺語，黑白片，二〇分鐘

報導金門島上農業經濟各方面的情況。金門人民在通力合作下，利用農復會援助的款項和現代農業技術，將原先的荒島變為耕地。

B 四三一

耕者有其田

國語，臺語，黑白片，四〇分鐘

自由中國土地改革的經過，包括一九四九年實施的三七五減租，一九五一年以公有土地出售給佃農的措施，以及一九五三年最後階段的『耕者有其田』計劃。

C 四三八

法律的產生

英語，國語，黑白片，三〇分鐘

敘述在民主社會中，普通公民的意見怎樣能成為國家的法律。說明美國的兩院制立法程序。新的法案須先經國會參眾兩院通過，再經總統簽署而成為法律。

B 八二〇

學習謀生之道

英語，國語，五彩片，二〇分鐘

敘述美國康乃狄格州教育廳為該州不擬升入大學而有志職業或技術訓練的青年而提供

C 七〇四 的教育設施，片中對該州設備良好的公立職業學校及學生皆有詳盡說明。我加入了四健會。

國語，五彩片，三〇分鐘

B 四三三 四健會運動在臺灣的情形。故事中心是一位姓李的農家男孩子參加四健會的活動後，他的田地生產量為之增加。

重見天日

、英語，國語，臺語，黑白片，一九分鐘

西柏林接待逃出東德政治壓迫的難民的設施，並將真正的逃亡者迅速轉送至西方的安置地點。

B 五九六 體小力偉

英語，國語，黑白片，二〇分鐘

敘述電晶體之發展和應用。

B 六一〇 原子時代新生活

英語，國語，五彩片，一八分鐘

本片攝製的目的，在向有原子裝置的地區的居民說明有許多保護工作人員及附近居民的安全措施，使他們安心。同時顯示原子能如何用來造福人類，促進進步。

A 一三一

蝗災
國語，黑白片，一〇分鐘

區。

A 一三四 壁畫的畫法

國語，五彩片，一〇分鐘

美國畫家賓頓表演完成一幅壁畫的重要步驟，以及為何可以達到光澤的色彩和立體的效果。

B 一三五 金堅玉潤

國語，五彩片，二〇分鐘

在美國製造的精細磁器。

B 一三六 清除瘧疾

英語，國語，黑白片，一五分鐘

敘述瘧蚊帶來瘧疾及如何撲滅的方法。

B 一三八

醫學的發展

英語，國語，五彩片，一五分鐘

自埃及時代到現在的醫學發展。介紹偉大的醫學家，並列舉醫學方面的各項重大進步。

B 四四八

人造富源

英語，國語，黑白片，二一分鐘

B 六八四

第福瑞斯特小傳

本片說明機器在過去一世紀，怎樣增加人類的生產能力，而有貢獻於增進生活水準。

英語，國語，五彩片，一五分鐘

C 一四一

現代電子學創始者，『無線電之父』第福瑞斯特的生活片段。

英語，國語，黑白片，二五分鐘

女歌唱家瑪麗安德遜的生活情形，和她歡喜唱的歌曲，包括，「致敬禮」，「啊！多美麗的城市」，「祂掌握了整個世界」，「十架犧牲」，「深河之戀」，「麥田戀歌」及「聖母頌」等。

B 一四二

醫藥

英語，國語，臺語，黑白片，二〇分鐘

敘述在醫學研究和診斷上利用原子能材料對於腦癌病人的效果，利用放射性元素，作為過制和找出疾病位置的材料。報導利用原子治療甲狀腺病、癌、動脈硬化等症的研究。強調指出了為了增進世界衛生，國際間交換原子能科學知識的重要性。

B 八三二

太空聚會

英語，國語，五彩片，一五分鐘

本片報導一九六五年十二月四日雙子星七號的成功飛行，十二月十三日雙子星六號的試行發射及隨後的四十八小時圓滿飛行，片中並敘述橢圓及圓軌道飛行及太空會合的技術

B 六二二

機械理論。
人與船

英語，國語，黑白片，一八分鐘

本片攝於臺灣東岸的南方澳漁村。這一漁港每天約有六百艘船出海。他們供應着自由中國一大部份的民食。本片是在附近海面捕魚三十年的黃老泰的真實故事。

C 六八〇

堪當大任

英語，國語，五彩片，三〇分鐘

在一個小村落中的四健會活動情形。兩個少年參加該會學習如何負責。

A 八一五

為民服務的人們

英語，國語，黑白片，一〇分鐘

本片報導美國的醫藥在入道與社會方面的情形，說明公共衛生在保健及預防措施方面之推展及其業務項目。

B 六八八

虱目魚的繁殖

國語，黑白片，二〇分鐘

示範培育和繁殖虱目魚的各種方法，

B 六八三

國家之興起

英語，國語，黑白片，一六分鐘

本片敘述美國的迅速發展及在十九世紀末葉和二十世紀初期工業的龐大擴展。本片是

C 一五一 由現代的繪畫和版畫，原始的照片和美國電影業供應的影片等攝製而成。
策定方針

英語，國語，黑白片，三〇分鐘

報導美國建立新國家所遭遇的困難。制憲大會的集會。聯邦憲法經長期辯論後卒獲通過。在哲佛遜任總統時，談判購買路易斯安那。路易斯和拉克的進行探測廣大的西部地區。建造國家公路，伊里運河，鐵路和輪船，加速向西移民，和擴大國內貿易。西北部各州的工業成長。西部地區英雄傑克森的當選為美國總統，顯示出美國這個最新部份的政治力量。西部新居地的生活，使人們認識到民主基本原則的重要。

A 一五三

鸚鵡螺號航經世界極點

英語，國語，黑白片，一〇分鐘

美國原子潛艇鸚鵡螺號在北極冰帽下作四天航行的事蹟。它的任務是在太平洋和歐洲間尋出一條新的最短路線。（自阿拉斯加的巴魯角至格陵蘭的新路線為一八三七哩）首先創導核子潛艇的李高佛海軍少將說明這艘潛艇上的原子反應器。鸚鵡螺號艇長安特森海軍中校獲得美國總統的授勳。

C 一五七

新大陸

英語，國語，黑白片，三〇分鐘

追記美洲的發現，早期歐洲探險家橫渡海洋；北美洲東部印第安人的生活 and 印第安文化與西班牙文化遭遇；西班牙的殖民，在加勒比海上的英國海盜，新英格蘭和南方早期居

B 一五九

紐約市水源

國語，五彩片，二〇分鐘

民的生活；其他民族遷居新大陸，世代相傳而使美國成為他們的故鄉；勞苦工作和新大陸資源使這個新居地成為繁榮的殖民地。本片將結束時介紹印第安人與向西擴展的法國人之間日增的衝突。

C 八一三

恐怖之夜

英語，國語，二六分鐘

本片利用實際戰爭背景描述越南人民在六年中不顧越共的恐怖襲擊而保持自由的決心，雖然南越人民因地形不利，難以防禦北越的侵略保衛他們的家園，但老百姓依然毫不畏懼過着每天正常的生活。片中並揭示共黨戰爭武器的來源及其滲透及恐嚇老百姓的叛亂方法。世界自由國家如西德，紐西蘭，奧大利亞，菲律賓等對越南人民生存奮鬥所作技術與醫藥的支援亦在片中有報導。

C 四五八

並非偶然

英語，黑白片，三〇分鐘

敘述美國一千二百所師範學校中對師資的選拔，訓練及專業的發展。

B 六一七

核子商船薩凡那號

英語，國語，五彩片，二〇分鐘

本片說明原子商船薩凡那號的建造情形，並解釋其對於未來核子動力海面船艦之建造的影響。

B 七一五 食物與營養

國語，黑白片，二〇分鐘

本片說明並示範營養對人之重要。

B 八二八 一枝小蠟燭

英語，國語，黑白片，二〇分鐘

本片報導由中國大陸逃出的難民在美國，南美州及英國的安置情形。

B 四六一 青年旅行會

英語，國語，黑白片，二〇分鐘

美國自行車協會今日已擁有旅宿設備。從事旅行的學生付出極少的費用可食宿於這種宿舍內。自由車協會的服務，滿足青年人探測新地方的渴望。

B 四六六 電影的起源

英語，國語，黑白片，二〇分鐘

自早期的複製電影到愛迪生於一八八九年發明電影機為止的電影起源的發展。本片並映出包含歷史大事鏡頭的早期電影。

B 八四九 越南鄉村重建工作

英語，國語，黑白片，一五分鐘

本片敘述一個越南鄉村重建隊在越共佔領過的村莊的建設情形，重建隊的工作人員協助村民重建家屋，學校，道路，並從事他種社區計劃。

B 六九二 探發太平洋

英語，國語，黑白片，二〇分鐘

本片顯示科學研究如何提高和外界隔絕的太平洋區域人民的生活水準；同時表明個人為謀生和自然搏鬥的力量之微弱。本片簡單地記述太平洋科學協會的工作——經由合作的研究以改善人類生活的科學成就。

A 二二二 抽象畫法

國語，五彩片，一〇分鐘

美國畫家奧哈拉介紹其水彩畫的抽象畫法，特別注重於畫面佈局和色彩的運用。

B 六七八 致力和平

英語，國語，黑白片，一五分鐘

本片為紀念故聯合國秘書長哈馬紹而攝，以推崇其對和平的努力與對聯合國的供獻。

C 四九四 石油與人類

英語，國語，黑白片，二七分鐘

這是克里歐爾石油公司在委內瑞拉活動的報導。指出經濟和社會的利益導致對外國投資的了解。

B 二二九 西海岸的人民

英語，國語，黑白片，二〇分鐘

介紹美國西海岸地理、人民和工業，說明工人和農人，消費者和生產者，美國和外國的貿易商之間的相互依存關係。

C 二三〇

古河化岩

英語，國語，五彩片，三〇分鐘

鈾的故事：敘述經過千萬年地質變化而成鈾礦的經過情形，介紹科羅拉多高原地帶的鈾礦，以及目前鈾的探測與開採和同位素的若干用途。

B 二三一

菲律賓的進步

英語，國語，臺語，黑白片，二〇分鐘

菲律賓於一九四六年七月四日獨立後，即重建在二次世界大戰中的毀損，其經濟及社會有長足進步，介紹該國歷史背景及美國與該國之關係。

C 二三四

自由之土

英語，國語，五彩片，三〇分鐘

介紹美國的紀念碑，紀念館，國家公園，歷史古蹟以及其對美國人民的重要性。本片包括：蒙梯賽羅山，林肯的隱居所和出生地，約塞密提和黃石國家公園。及其他各地名勝。

B 五七二

汽車城風光

英語，國語，五彩片，一七分鐘

美國密西根的底特律市自一七〇一年創建以來的故事。該市在文化和工業方面的發展和由四輪馬車時代轉變為汽車時代。介紹該市大街、小巷、貧民窟、碼頭、工廠、郊外和公共遊樂地區等。

B 二三八

飼養家禽

英語，國語，黑白片，二〇分鐘

關於來亨鷄和普里木斯鷄的飼養。

B 二三九

電化農村

英語，國語，黑白片，二〇分鐘

敘述電力對提高農村生活水準的重要性。

C 七六六

南極電源

英語，國語，五彩片，三〇分鐘

在南極洲七區麥克墨杜建立一個核子電力鎮。裝設核子發電廠。

A 六一九

耕耘機

國語，臺語，黑白片，一〇分鐘

臺灣省農會為了提高農民使用耕耘機的興趣而舉辦的耕耘機展覽和示範大會。

B 七六八

詹森總統

英語，國語，五彩片，一五分鐘

本片說明由於甘迺迪總統的亡故美國總統職權的轉移，片中顯示詹森總統接管美國政

府。

B 八〇三

總統與記者

英語，國語，五彩片，一六分鐘

介紹詹森總統透過新聞與人民聯繫及溝通關係，片中包括正式及非正式的記者招待會，其他的公開場合如民權法案簽署等。

B 四八七

電學的原理

國語，五彩片，二〇分鐘

用卡通片介紹電的原理，物質的原子構造和原子內電子的活動。闡釋伏特、安培和歐姆的定義，電壓單位，電流和電阻的原理，電磁、磁場、導體和非導體等。磁場在發電中的功能，以及電力的應用。

B 六六〇

印刷圖案製作家

英語，國語，五彩片，二〇分鐘

介紹美國傑出繪圖家的創造力，顯示各人在印刷藝術方面的技巧與成就。

A 二四四

小鎮的問題

英語，國語，黑白片，一〇分鐘

紐約州布立漢頓小鎮如何以民主方式來解決公共問題，本片並報導鎮民委員會的工作概況。

A 七八六

武力實況

英語，國語，五彩片，一〇分鐘

本片敘述美國第七艦隊為支援美國對亞洲國家所作承諾所作的活動情形。

B 八〇四

太陽神計劃

英語，國語，五彩片，一三三分鐘

本片報導發送三人至月球的計劃。

B 七六三

電視轉播衛星

英語，國語，五彩片，一八分鐘

「遠星」衛星的順利發射和運轉。「遠星」衛星為民營企業和政府聯合舉辦的一項通訊計劃。首次經由衛星轉送越洋電話。

A 六二七

鯉魚的人工繁殖

臺語，黑白片，一〇分鐘

本片示範一家臺灣飼養場培育和繁殖鯉魚的各種方法。

B 六六一

開發的成就

英語，國語，黑白片，二〇分鐘

這部片子顯示外人投資對於促進國家經濟發展及人民生活改善的功勞。美國人在拉丁美洲，中東及遠東的投資已使這些地區的民生獲得廣大而迅速的改善。

C 四八九

公共衛生護士

國語，五彩片，三〇分鐘

敘述小鎮上公共衛生護士的多種責任，其工作包括醫療個別病人，計劃社區的活動，並指導學校的健康衛生措施。

A 五〇二 盲人的再生
國語，黑白片，一〇分鐘

精紐約「盲人工業之家」的工作來顯示對各個人的關懷。其工作包括教育盲人克服殘疾而走上獨立的生活，姿態的改正，身體訓練，意向測驗，工業訓練和發展新技能。

C 七三七 預演
英語，國語，黑白片，二六分鐘

介紹紐約州羅契斯特的伊斯曼音樂學院的地位及其對社會的影響力，以及該校四入弦樂隊和交響樂隊的演奏。

B 五〇七 合歡橋
國語，臺語，黑白片，二〇分鐘

C 二五二 百日路
敘述農田灌溉的重要性，特別強調輪流灌溉對臺灣農田的適宜性。

英語，國語，臺語，黑白片，三〇分鐘

本片在希臘攝製，敘述一個小山村的人民共同工作，為了與外界保持接觸，克服困難，在百日內完成一條道路，以慶祝他們的聖宴節。本片強調該區住民的合作精神和決心，意外而受歡迎的美國技術援助，以及該路對當地人民的利益。

A 六二〇 撲滅野鼠

國語，臺語，黑白片，一〇分鐘

臺灣的農民參加農村復興委員會所發起的運動，撲滅約四千萬隻出沒於農田的野鼠。

A 二五一 鄉村郵政

國語，黑白片，一〇分鐘

敘述美國鄉間郵政系統，鄉村享受和大城市的一樣的郵政服務，但並不另外收費。

C 六四八 聖勞倫斯動力計劃

英語，國語，五彩片，三〇分鐘

本片介紹位於美國與加拿大間的聖勞倫斯動力計劃的建設情形。

A 七八三 農神號太空艙

英語，國語，五彩片，一〇分鐘

報導有關世界最大火箭之設計製造及發射之基本技術及科學研究。

A 七七四 弦樂器製造學校

英語，國語，黑白片，一〇分鐘

弦樂學生在一所專門訓練提琴家的獨特學校中的學習情形。

B 五二五 科學的進展

英語，國語，臺語，黑白片，二〇分鐘

報導原子能發電，原子能灌溉以增加糧食作物的生產和保存食物。同位素應用於工業

產品精密厚度的控制和造路方面土壤強度的測定，癌症和心臟病的治療，以及光合作用的研究等項科學進展。

C 六八一 童子軍的道路

英語，國語，五彩片，三〇分鐘

介紹美國各種童子軍的活動。

A 二六〇 卷畫

英語，國語，五彩片，一〇分鐘

本片根據美籍中國畫家曾景文一九五四年在文化交流計劃下，旅行世界，一宗獨特的『向國務院報告』畫卷。曾景文在旅行中所作的畫是描寫他對所訪問各國的印象。

A 五〇八 海獅棒球隊

英語，國語，黑白片，一〇分鐘

本片故事敘述一位被認為年紀太輕不能參加成人棒球的孩童，在參觀動物園時，對海豹如何接取管理人投擲食物發生興趣。經過辛勤的練習以後，他也能够正確地把食物投擲給海豹。由於這項新學得的技巧，該孩童獲准參加棒球隊為正式的隊員。本片強調協合作，體育精神和從實際動作中學習。

C 五二八 為前途投資

英語，國語，黑白片，三〇分鐘

紐約證券交易所的歷史與其工作情況。對美國工業成長的作用和對美國經濟制度的功

能。

B 八〇一 進步的盾牌

英語，國語，黑白片，二〇分鐘

敘述共黨在東南亞的侵略及東南亞公約的誕生。

D 二六三 捕蝦人

英語，國語，臺語，黑白片，六〇分鐘

美國路易斯安那州南部墨西哥灣漁人捕蝦的方法和問題，遠洋拖網船和小型捕蝦船的作業。本片介紹一位捕蝦人的家庭和鄉鎮生活。

C 八三三 自由的力量

英語，國語，五彩片，三〇分鐘

報導中華民國在健全的經濟發展方面的大進展，更報導農業及工業的進步及美援的功

A 六六五 廚房洗槽的做法

國語，黑白片，一〇分鐘

本片介紹如何建造一個適於農家經濟衛生的洗槽。

C 二六四 基本三課

英語，國語，五彩片，二九分鐘

美國小學一年級的學童學習閱讀、寫作和算術。本片介紹一位幼童他需要並得到一輛

A 五一一 自行車的故事。(採用新式教授法)
軟式棒球術

英語，黑白片，一〇分鐘

B 六七七 藉慢動作鏡頭講解擲球、接球、運球、擊球的技術，接手與擲手的協調合作，以及利用普通鏡頭介紹比賽的情形。

東南亞公約衛護自由

英語，國語，黑白片，二〇分鐘

B 二六九 本片為一九六一年在曼谷舉行的東南亞公約外長會議及軍事顧問會議實況。
各州與全國

英語，國語，黑白片，二〇分鐘

敘述美國各州和聯邦政府的關係。簡介各州所保留的權利，和義務，以及州政府的職權，包括相互的關係和在憲法下的權力。

B 二七〇 美國國史館

英語，國語，五彩片，二〇分鐘

C 七六五 訪問美國國史館，敘述保存國家重大歷史文獻和政府檔案所設計的方法，介紹該館為國家利益或私人研究目的服務的效率。

冰下之城

英語，國語，五彩片，三〇分鐘

介紹美國在格陵蘭島冰帽下建造的一所利用核子動力的美國陸軍北極研究室的結構情形。

B 七一四 李麗珠的故事

英語，國語，黑白片，二〇分鐘

一位中國少婦眼中所看到的臺灣鄉村發展和經濟進步的情形。

A 六六四 怎樣節省燃料及粉刷房屋

國語，黑白片，一〇分鐘

本片示範一種提高臺灣農家所用的爐灶效率的簡易方法和如何打掃、粉刷房屋。

A 七七六 半工半讀的學生

英語，國語，黑白片，一〇分鐘

一位美國青年學生工程師半工半讀的經驗。

B 六四九 星際航空概況

英語，國語，五彩片，二〇分鐘

報導美國火箭研究計劃及發展太空科學的理論展望。有關人工操縱人造衛星的各種學問亦在討論之列。

C 二七四 遍佈全國的交響樂

英語，國語，黑白片，五〇分鐘

描述美國交響樂團對美國文化生活的重要性。

C 二七五

空中交響樂團在日本
英語，國語，黑白片，四〇分鐘

報導空中交響樂團（前國家廣播公司交響樂團）於一九五五年環遊日本的情形。本片所介紹的演奏節目計有：白遼士作品第九號『羅馬巡遊節』；莫札特的第三十五號D大調交響曲『哈夫納』第一章；柴可夫斯基的『胡桃鉗組曲』內之『花之圓舞曲』；鮑羅定的『伊果王子』內之『韃靼舞曲』，貝多芬的作品第六十七號『第五交響曲』，C小調。本片無說明。

C 七三五

交響樂之塔
英語，國語，黑白片，三〇分鐘

介紹波士頓交響樂團的歷史、祖籍不同的團員、社會各階層的聽眾，對美國交響樂團發祥地波士頓歷史亦作簡單介紹。

B 二七八

坦格塢音樂學校
國語，黑白片，二〇分鐘

介紹麻薩諸塞州的坦格塢音樂學校，樂隊演習，學校生活和柯賽威斯基在夏季演習情形。

B 六五九

甘迺迪總總在歐洲
英語，國語，五彩片，二〇分鐘

故甘迺迪總統訪問巴黎，維也納及倫敦。包括他在各地發表的重要政策聲明，公開演

A 〇九一

說及返國後在廣播電視中向美國人民的報告。
網球冠軍
英語，國語，臺語，黑白片，一〇分鐘

美國女子網球名手吉布森重要的比賽成績，她於一九五七年在森林山贏得美國女子網球單打冠軍。

C 三〇〇

田納西大壩
英語，國語，黑白片，三〇分鐘

本片描述在經過數十年貧窮和失望以後，土地和人民對新生活，新工業和繁榮的再覺醒。這種成就就是經由一項田納西流域水力發電計劃而成。本片介紹規模宏大的田納西發電工程，使土地開墾農業進步，給人民較佳的生活，而對實際民主有所貢獻。

C 七〇〇

第十屆太平洋科學會議
英語，國語，五彩片，三〇分鐘

介紹第十屆太平洋科學會議所在地夏威夷的環境，以及太平洋地區的若干共同問題，這些問題即是這個國際會議詳細研究討論的問題。與會代表的實地視察，顯示出夏威夷的風光美麗。

A 六七一

休戚相關
英語，國語，黑白片，一〇分鐘

詹森副總統訪問柏林時，一千五百名增援柏林的美軍亦同時抵達。

B 二八二

無須枉死

國語，黑白片，二〇分鐘

報導印度政府在世界衛生組織與美國援助合作下所推行的五年計劃以改進衛生設施降低嬰兒死亡率。

C 三四八

自動化工業

英語，國語，黑白片，三〇分鐘

分析自動化工業的利益，自動化工業製造的必要條件，以及改裝普通設備用於自動化工業生產。列舉自動化工業產品和標準以確定何等工業可以採用自動化。

B 二八三

菲律賓報導

英語，國語，黑白片，二〇分鐘

菲律賓的簡史概述其種族和文化的背景，地理，經濟和政治的發展。

B 五四七

金門

英語，國語，黑白片，一五分鐘

A 七七三

介紹一九五八年八月共匪瘋狂砲轟金門期間當地人民所保持的鎮靜，並摧毀的村莊。珍視我們的土地。

英語，國語，黑白片，一〇分鐘

B 七四一

一位自然愛護主義者與一羣小學生們在山上宿營一星期，教他們珍視自然。三千年的中國藝術

英語，國語，五彩片，二〇分鐘

本片藉保存在臺灣台北中山故宮博物院的文物，對中國三千年的藝術，依照年代先後，順序介紹。

A 六八九

雷虎小組訪越

國語，黑白片，八分鐘

中國空軍雷虎小組於一九六一年訪問越南，在熱烈的越南觀眾面前，九架噴射戰鬥機表演驚人的飛行技術。

B 五四二

馬尼刺之行

英語，國語，臺語，黑白片，二〇分鐘

本片以特寫的鏡頭簡短的報導菲律賓獨立後在經濟社會方面的進步，片中故事得自一農夫的口述，該農夫自貝利奧至馬尼刺參加其兒子畢業典禮，沿途看到他的國家於過去十年中在重建計劃及農業改良方面所獲的成就。

B 二八六

時計之發展史

國語，黑白片，二〇分鐘

敘述發明鐘錶的故事。

C 二八九

爭取自由

英語，國語，黑白片，三〇分鐘

在爭取自由的政治背景下，映出一段法國人與印地安人的戰爭，殖民地因為有政治自

由和個人自由的傳統以實施自治政府的經驗故對英國皇室之限制及課稅漸感不耐，戰爭發生後，十三個殖民地發表獨立宣言，華盛頓率軍參預各主要戰役，各殖民地終獲自由，繼續向西發展。

B 二九〇 開更大眼界

國語，黑白片，二〇分鐘

B 七八二 介紹供眼鏡，望遠鏡和顯微鏡等用途之用的玻璃鏡片的生產及其原理。保持和平

英語，國語，五彩片，二〇分鐘

C 二九二 本片敘述美國軍事力量在地面，海洋及空中對保持和平所作的供獻。鞋匠政治家

英語，國語，五彩片，三〇分鐘

本卡通片生動而扼要的敘述美國獨立戰爭的歷史，其重點在說明個人對此一民主社會的供獻。

C 八二五 前程在握

英語，國語，五彩片，三〇分鐘

C 六一三 本片敘述美國對正開發國家的非軍事性質的援助情形，片中說明對薩爾瓦多，波利維亞，印度，巴基斯坦及依索比亞等國的援助計劃。培植未來

英語，國語，黑白片，三〇分鐘

本片描述彭琪琪博士的生平，他的少年，他祖母鼓勵他繼續求學對他的影響，他的學生時代，他日後成功為美國有名的政治家及諾貝爾獎金獲得者，本片強調美國承認個人才能及機會自由均等。

B 六九七 學術之塔

英語，國語，五彩片，二〇分鐘

一個不同種族的團體在匹茨堡大學的『學術之塔』共同致力建立十八國學術室。這個十八國文化的紀念塔也是匹茨堡大學推行國際文化教育交換計劃的一個象徵。

B 二九六 原子時代的人才訓練

英語，國語，黑白片，二〇分鐘

本片是美國原子能委員會主持下的外國科學家核子物理訓練計劃的紀錄片，報導北卡羅來納大學，賓夕法尼亞大學，橡樹嶺核子研究所和伊利諾州拉格蘭吉的國際核子科學工程學院（國立阿岡實驗所的一部份）的活動，以及賓夕法尼亞州白濱埠的核子反應器的建造情形。

C 七八〇 勞苦的收穫

英語，國語，臺語，五彩片，三〇分鐘

敘述越南國家的興起，遭遇危機及未來的希望。

A 五三九 肺癆病

英語，國語，五彩片，一〇分鐘

A 六二九

憂患之島
肺癆病的特徵，診斷和治療。解釋傳染和再傳染的過程，強調預防措施和有效治療。

英語，國語，黑白片，一〇分鐘

本片為甘迺迪總統對美國編輯人協會演講古巴情勢時之紀錄摘要，警告共產主義對西半球的危害，美國對主動防衛自由的承諾，片中並有甘迺迪總統把共黨在古巴，匈牙利，及遠東各地所作所為與其諾言之相矛盾作一對比。

B 三〇五

英語，國語，臺語，黑白片，二〇分鐘

本片說明美國的特質與抱負，美國對各種主義，知識及精神自由個人價值所作的供獻，顯示美國軍事及工業能量，農業及科學潛力。

D 三〇七

美國

英語，國語，臺語，五彩片，四〇分鐘

本片是一部美國遊記，同時點綴出美國是一個多采多姿的國度，并特別介紹大峽谷，新英格蘭，大湖區，中西部，塔基山，西南部和亞熱帶的南方。描述各個地方的特徵，強調美國是綜合各種不同習慣，興趣和價值合而為一的國家。

B 三一四

大豆

國語，黑白片，二〇分鐘

介紹大豆在工業及醫學等方面的多種用途。

A 三一七

鄉村與學校

國語，臺語，五彩片，一〇分鐘

本片是特別為鄉村觀眾攝製的卡通片，介紹教育的價值及其對人類福祉的貢獻。教育提高村民生活水準和增加村民對外界的智識，從而為個人、家庭和鄉村帶來幸福。強調識字對兒童的重要性。

A 三一八

鄉村與技術

國語，臺語，五彩片，一〇分鐘

本片是特別為鄉村觀眾攝製的卡通片，示範採用新式農業方法的利益。農業指導員敘述他在勸導村民們試用新式耕作方法時所遭遇的困難，最後他給村民們放映一張影片描述在美國的類似情形。當農民們採用新式較佳的方法時，解決了土壤沖蝕和貧瘠的問題。村民們的瞭解得使態度改變而獲豐收。

A 八〇七

太空漫步

英語，國語，五彩片，一〇分鐘

本片報導太空人麥迪維特與懷特駕雙子星四號飛行太空情形，懷特並在太空艙外漫步，二十分鐘。

A 五五四

水，汝之友；汝之敵

國語，五彩片，一〇分鐘

人類的糞便如何染污水而引起疾病。簡單的保護措施可以預防泉水和井水的不潔，水亦可由煮沸而除去雜質。

B 六〇八 前途

英語，國語，黑白片，一五分鐘

C 五五五 獵犬訓練法
本片介紹由美國麻州理工學院物理科學教學研究會所研得的新的中學物理教學法。

英語，國語，五彩片，三〇分鐘

A 七八八 獵犬是獵人的好友，獵獲物的尋回是狩獵一半的成功，英國的長毛犬、便犬，西班牙的長耳犬都可訓練成獵犬，服從命令，辨別手勢是獵犬必學的課程。我們必須克服

英語，國語，黑白片，一〇分鐘

C 三二二 華府觀光
本片為詹森總統向國會演說請求通過民權法案中的投票權。

英語，國語，五彩片，三〇分鐘

介紹國際性首都華盛頓及其簡史。敘述美國政府立法，行政和司法三大部門的結構和它們在華府大廈的外貌。觀眾將可欣賞到一般遊客所常到的風景，並約略介紹華府各業居民的生活。

B 五五八 當共黨來後

國語，臺語，五彩片，二〇分鐘

卡通片。敘述一位鄉村學校教師和他的家人在中國大陸上生活的情形乃至共產黨來後所發生的事情：家庭折散，財產沒收，親人分離和喪失權利與自由。

A 六五五 威瑪盧道夫，奧林匹克錦標選手

英語，黑白片，一〇分鐘

美國徑賽選手威瑪盧道夫曾在世運會中獲得三個金牌，本片是一九六〇年她在羅馬世運會中的比賽情形，以及她凱旋家鄉——田納西州納希維爾——受到的歡迎。另外，還介紹她的家庭生活，大學生活，她的朋友，以及她在美國國內參加的徑賽。

A 五六一 可怕的瘧疾蚊

國語，黑白片，一〇分鐘

瘧疾病對身體和經濟的影響。瘧疾的起因、預防和有效的醫藥治療。

C 六七二 手與心

英語，國語，臺語，黑白片，三〇分鐘

關於一個斷臂的韓國人在大田傷殘中心及農村習藝所接受醫護及訓練，恢復謀生能力的經過。這是美國教會世界福利會及基督教福利會聯合會工作的一部份。

C 七四〇 要使音樂飄揚

英語，國語，五彩片，三〇分鐘

介紹美國猶他州鹽湖城的摩湖城的摩門教會唱詩班的情形。

B 三三一

美國自然科學博物館

七八

英語，黑白片，二〇分鐘

C 三二八

威爾遜——明日的發言人
本片介紹紐約美國自然科學博物館的内部情形。

英語，國語，黑白片，三〇分鐘

B 三三五

美國威爾遜總統在第一次世界大戰前後的二年任期內的工作和理想。他對和平不懈的努力，對戰爭的厭惡和對國際聯盟的熱心。

同心協力

英語，國語，黑白片，二〇分鐘

A 六二八

報導各國科學家和政府從事區域和國際合作以發展原子能和平用途。

太空實驗

英語，國語，黑白片，一〇分鐘

B 七八一

介紹美國太空人謝彼德五月五日自甘迪迺角出發飛行太空的經過，美國及外國新聞記者採訪情形，他們對於美國第一次太空飛行的準備及科學上的目標均獲有充份的資料。

紐約世界博覽會
英語，國語，五彩片，一九分鐘

C 六四三

本片介紹在紐約世界博覽會中的八十個國家的各項展品。
快樂家庭

英語，國語，五彩片，三〇分鐘

描述在中國大陸上，一個農家遭共黨壓迫及其正在求學的儿子，被共黨麻醉，因而家庭破散。

C 八〇五

美國畫家

英語，國語，五彩片，三〇分鐘

十九世紀美國藝術家溫斯陸，荷馬的作品紀錄片。

B 三三七

國立黃石公園

國語，五彩片，二〇分鐘

介紹美國最著名的國立公園之一。

C 六五〇

X—十五號

英語，國語，五彩片，三〇分鐘

美國太空飛船X—15號的發展及試驗。X—15號兼有飛機及太空的性能。

D 三三九

湯川軼事

英語，國語，臺語，黑白片，四〇分鐘

一位日本科學家的故事。他應邀赴美國參加研究所的工作，和很多來自各地的科學家一起計劃及研討他們個別的工作。

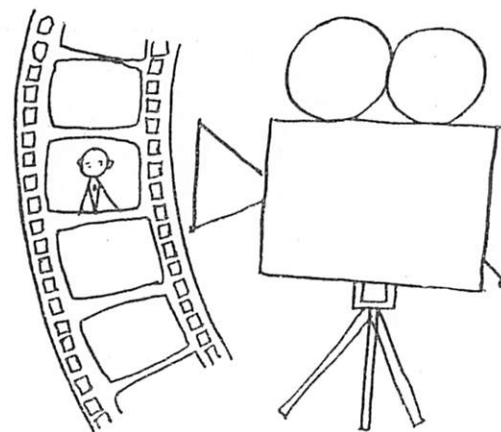

FILM CATALOG

The United States Information Service is at your service. USIS in the Republic of China functions to strengthen the ties of friendship, understanding, and mutual advancement which exist between the two nations.

USIS personnel are at your service to help in any way they can to make USIS materials and services available to you. A variety of informational and cultural programs are available through the following offices: USIS Taipei, USIS Taichung, USIS Kaohsiung, USIS Tainan, reading rooms in Chiayi and Pingtung, and self-servicing reading rooms on Kinmen and Matsu.

USIS in Taiwan is composed as follows:

The Press and Publications Section issues news releases and background information to newspapers, magazines, the Chinese government and civic organizations. It also prints and distributes several magazines and photo reviews.

USIS Taipei operates a library and an auditorium at 54 Nan Hai Road which offers a cross-section of American books and magazines and regular programs of recorded and chamber music, film showings, lectures, art exhibits and other cultural activities. The Cultural Affairs Section also administers many U. S. Government-sponsored programs on cultural exchange and book translation.

The Radio Section produces a variety of programs in Mandarin, Amoy and English for domestic audiences on Taiwan, the Voice of America, and stations in the Far East and Southeast Asia serving overseas Chinese communities.

The Motion Picture Section lends American documentary films listed in this catalog to schools, professional and civic groups. It also produces documentary films featuring life and progress in Taiwan for showing to local and overseas audiences.

The Television Section provides American-produced films to commercial and educational television station outlets on Taiwan. Some of the films are English instructional, while others are newsreel clips and feature length programs about significant events in the United States, other parts of the world and in space. The television section also provides footage about the Republic of China and its newsworthy events to the United States Information Agency for world distribution.

Any films in the USIS film libraries are available for loan although some are in limited supply and loan requests should be made if possible well in advance of the requested viewing date.

If any organization requires film which is not regularly

available, USIS will request the film on special loan from the United States Information Agency in Washington. USIS Taiwan will make every effort to meet such requests as a part of its service, but often it takes several months to trace and obtain such film, and sometimes the film itself is not available.

This catalog has been compiled for the convenience of organizations and institutions on Taiwan which use the USIS film collection. The catalog lists films available as of January 1, 1967, with supplemental lists appended as additional loan material becomes available. ✓

NOTES ON BORROWING

1. The facilities of the United States Information Service in the Republic of China are open to all organizations which have satisfactorily completed registration loan forms. Forms are available at USIS offices.
2. Organization projectors initially must be inspected by USIS, and the fact established that a competent projectionist will handle the loan film. USIS will, without charge, train as a projectionist anyone designated by the borrowing organization.
3. There is no charge made for the loan film, but borrowers are held responsible for the safe return of the film.
4. All films are 16mm optical sound. Many are in color but some are in black and white. Most prints are available in Mandarin and English versions. Some are available in Amoy.
5. A report form is supplied with each film program. Borrowers are requested to fill out the information asked on the form

so that USIS may endeavor to better serve all borrowers. Any physical damage to the film should be reported when the film is returned.

6. Borrowers may list alternate choices in case the film requested is temporarily not available, on loan, or cancelled.

FILM CARE

Points about film care are outlined to help prolong the life of each film. Longer film life will allow better service to each borrower.

1. Clean the projector, and especially all moving parts which the film contacts, before threading the projector. Most film damage occurs because of scratching during projection.
2. Do not use sound film on double sprocket silent film projectors. Such use will ruin the sound track.
3. Once the film is threaded, turn several frames of it manually in the machine. This will prevent damage caused by driving the film with the motor in the event of incorrect threading.
4. If the machine makes unusual noises during projection, stop the machine and check the film sprocket holes to make sure they are not being stretched or torn.
5. The operator should stay within reach of the projector during the entire time the film is being shown. If a film break occurs, be sure to note the fact when the film is returned so that it can be repaired for the next borrower.

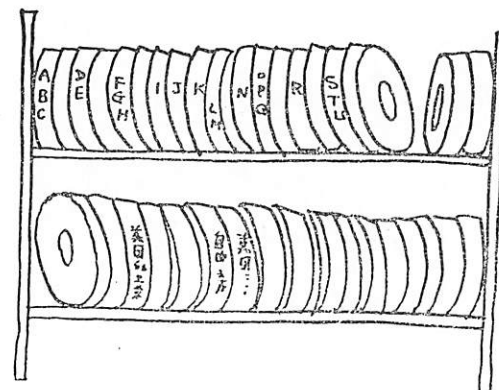

SUBJECT TITLES

Agriculture
Architecture and Engineering *
Arts and Music
Atomic Energy
Aviation, Space and Missiles
Communications
Conservation
Education
Fishing and Forestry
Industry and Labor
International Relations
Journalism
Libraries and Museums
Military
Occupations
Personalities
Public Health and Welfare

Religion
 Republic of China
 Science
 Sports and Recreation
 Transportation
 United Nations
 United States
 Women
 Youth

FILM LIBRARY HOURS

The film libraries at Taipei and Taichung are open from 1:30 until 5:00 p.m. Monday through Friday.

The film libraries at Kaohsiung and Tainan are open from 8:00 until noon and from 1:30 until 5:30 Monday through Friday.

All libraries are closed on Chinese and American holidays.

Following is a list of film available at the libraries under each subject title.

The call number of the film is to the left of the title, and the page on which a brief description of the film may be found is to the right of the title.

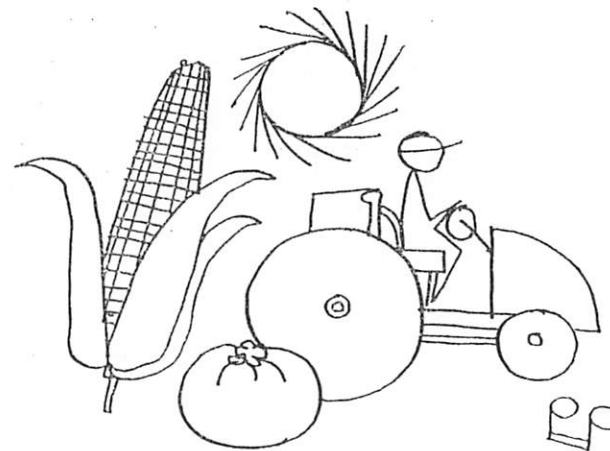

AGRICULTURE

B 007	Agriculture, Industry and Power.....	47
C 742	Agriculture USA	47
D 817	A Day on An American Farm.....	59
A 072	The Etawah Story	61
B 750	Harvest of An Atomic Age	68
B 405	Hog Industry	69
B 122	Killing Weeds	75
B 435	Life for the Land.....	77
B 440	Los Banos Story	79
A 137	Man Learns to Farm	80
B 140	Man of the Land	80
B 147	Men Who Grow Cotton	82
C 717	More than Mountains More than Gold.....	82
B 849	The Other War.....	86
B 235	Planning for Plenty.....	89
A 238	Poultry Raising	89

B	239	Power and the Land	89
A	619	Power Tiller.....	90
A	627	Propagation of Carp.....	92
B	507	Reunion Bridge.....	94
A	620	Rodent Control	95
B	288	Today's Chicks	107
B	791	The Valley Revisited	111
B	314	The Versatile Soybean	111
C	841	Vietnam: The Other War	111
A	318	The Village and the Technician	112
B	325	What A Land Tenant Should Know	114

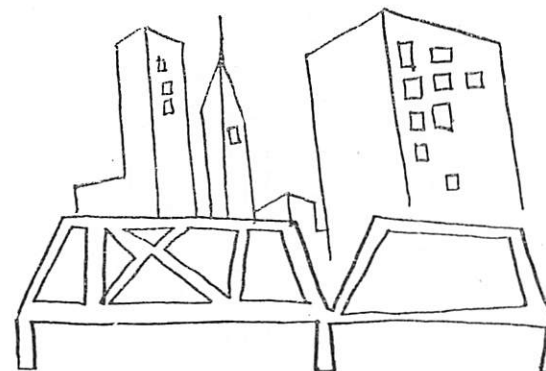

ARCHITECTURE AND ENGINEERING

B	814	Architecture USA	49
B	354	Bridging the Golden Gate.....	54
C	633	Building A New World	55
B	829	Building for Tomorrow	55
C	575	The Eighth Sea	61
D	585	The New Age of Architecture	83

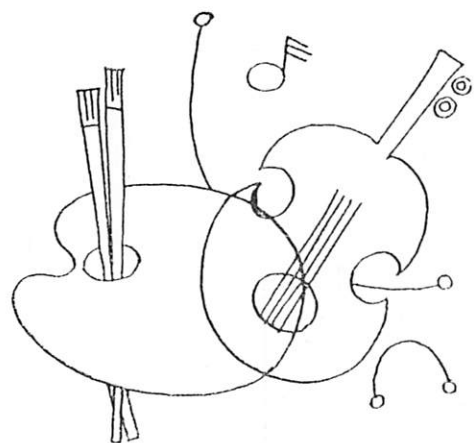

ARTS AND MUSIC

D	827	American Vision	49
C	696	Art Heritage	50
C	590	Art in the Western World	50
B	729	Art of Chinese Painting.....	50
B	621	Art of Lee Hsiang-Fen	50
B	588	Art of the Maya	51
B	846	Art Scene USA.....	51
B	023	Asian Artists in Crystal	51
D	694	Boston Symphony Orchestra.....	54
A	580	Charley Russell's Friends	56
A	691	Chinese Art Treasures	56
C	736	Concert Tour - USA	57
C	060	Creative Art in Rural America	58
C	062	Dance to Freedom	58
B	698	Design for Music	60
B	067	Dong Kingman	60

C	821	Eulogy to 5:02	62
C	076	Face of Lincoln	62
B	380	Family of Man	63
B	651	Fiddler's Festival	63
C	100	Highland Woodcarver	69
A	104	House	70
C	118	Jascha Heifetz - 103.....	74
C	119	Jascha Heifetz - 104.....	74
A	123	Korean Art Masterpieces	75
✓ C	124	Lady from Philadelphia	76
B	831	Lincoln Center, the Place and the Idea	78
A	134	Making of a Mural	79
C	141	Marian Anderson	80
C	840	More Interesting People.....	82
C	746	Music in the Forest.....	28
C	583	New England Portrait.....	83
B	467	Oriental Brushwork	85
B	466	Origins of the Motion Picture.....	85
A	222	Painting an Abstraction	86
B	495	Painting Clouds.....	86
A	496	Painting Crowds of People.....	86
A	223	Paintings of the New World.....	86
C	233	The Photographer.....	88
B	660	Printmakers	19
B	248	Recital No. 1	93
B	249	Recital No. 2	93
C	737	Rehearsal for Tomorrow	93
C	253	Artur Rubinstein, No. 101.....	95
C	254	Artur Rubinstein, No. 102.....	95

A	774	School for Strings	95
A	260	The Scroll	96
C	274	Symphony Across The Land	101
C	275	Symphony of the Air.....	101
B	843	Still More Interesting People	99
C	735	Symphony Road	101
B	546	Tailgate Man from New Orleans	102
B	278	Tanglewood Music School	102
B	741	Three Thousand Years of Chinese Art	105
C	293	Arturo Toscanini	106
C	324	Western Symphony.....	114
C	740	With Music Ring	115
C	805	Yankee Painter	117

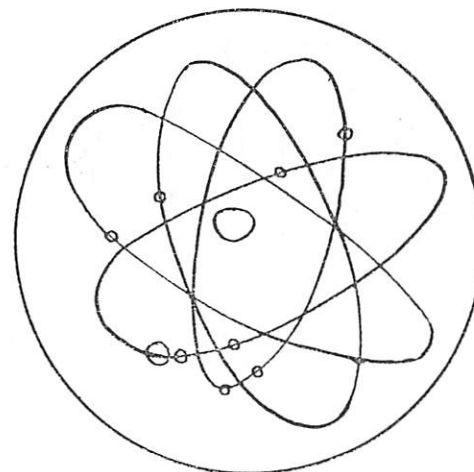

ATOMIC ENERGY

✓ B	340	A Is for Atom	47
B	007	Agriculture, Industry and Power.....	47
B	751	Atomic Weatherman.....	51
C	749	Atoms for Space	51
A	743	Basic Principles of Power Reactor.....	52
C	357	Blessing of Atomic Energy	53
B	360	Borax	53
B	750	Harvest of An Atomic Age	68
B	113	Introducing the Atom	73
B	610	Living with the Atom.....	78
C	777	Man and Radiation	80
B	142	Medicine	81
C	765	Story of Camp Century	99
B	335	Working Together	116

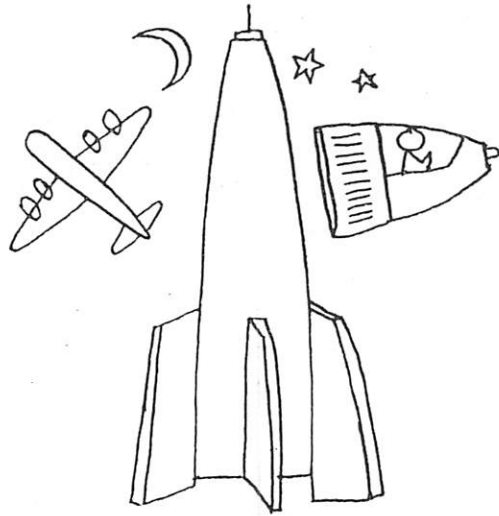

AVIATION, SPACE AND MISSILES

A	802	Above the Earth and to the Moon.....	47
B	732	America - Europe - America (Telstar 2).....	47
C	749	Atoms for Space	51
B	855	Behind the Spaceman	52
A	065	Defensive Sky Power	59
B	811	Destination Man	60
C	606	Exploring by Satellite.....	62
A	662	Fifteen Days in Space.....	63
B	810	The Flight of Gemini IV	63
C	718	Friendship Seven	65
A	703	John Glenn Orbits the Earth.....	74
C	790	Lunar Bridgehead.....	79
B	832	Meeting in Space	81
B	748	Our Nearest Star	86

A	618	Pioneer in Inter - Planetary Space	88
B	804	Project Apollo - Manned Flight to the Moon	91
B	819	Project Gemini: Mission Concept	91
B	763	Project Telstar	92
A	783	Saturn Space Vehicle	95
B	649	Survey of Astronautics.....	101
A	807	Walk in Space.....	112
A	628	World Watches An Experiment in Space	116
C	650	X-15	116



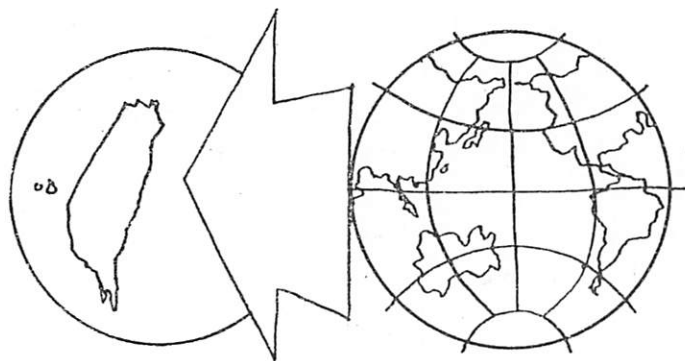

COMMUNICATIONS

B	732	America - Europe - America (Telstar 2)	47
A	752	Krystallos	75
B	596	The Little Giant	78
C	842	Live Via Early Bird	78
B	763	Project Telstar	92
A	251	R. F. D. (Rural Free Delivery)	95
B	778	Syncom	102



CONSERVATION

C	102	Hoover Dam	70
B	426	Irrigation Farming	73
A	133	The Magnetic Bottle	79
C	506	Rainbow Valley	93
B	507	Reunion Bridge	94
C	648	St. Lawrence Power Project	95
C	300	T. V. A.	103
B	791	The Valley Revisited	111



EDUCATION

C	730	American Field Service Story	48
B	015	Antioch College	49
B	616	Beyond Silence	52
B	794	Bridge to Tomorrow	54
B	721	Campus International	55
C	674	Center of Learning	56
C	064	Dark Interlude	58
C	640	Dartmouth Visited	58
B	068	Education for Better Living	61
C	727	The First Hundred Years	63
C	668	Growth of A Language	67
C	699	Harvest of Learning	68
C	772	Knowledge and Ideas	75
B	820	Learning to Earn	76
C	824	Look North	79
B	440	The Los Banos Story	79

B	457	A New Kind of School	84
C	458	Not by Chance	85
B	728	Personal Report #2 (Secondary Education)	87
C	737	Rehearsal for Tomorrow	93
A	774	School for Strings	96
B	258	School in Centerville	96
C	264	Skippy and the Three R's	98
B	637	Steelworkers' University Institute	99
A	776	Student Engineer	100
A	799	Student Teacher	100
B	278	Tanglewood Music School	102
B	723	Teaching English Conversation	102
B	632	Teaching English Grammar	102
B	545	Teaching English Naturally	102
B	851	Teaching English Pronunciation	103
C	281	That We May Better Serve	103
A	773	This Land	104
B	697	Tower of Learning	108
B	296	Training Men for the Atomic Age	108
A	317	The Village and School	111
B	608	The Way Ahead	113

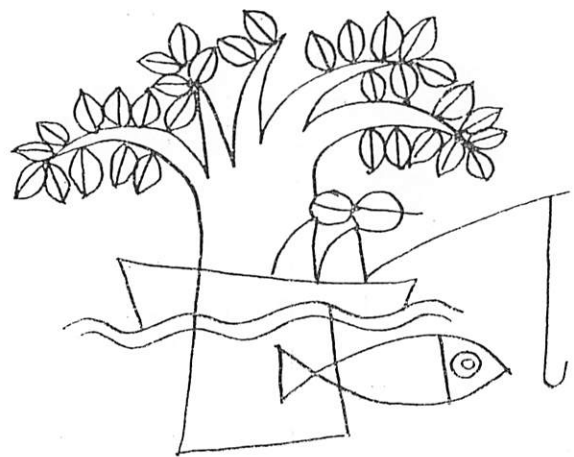

FISHING AND FORESTRY

B	002	Chesapeake	56
B	394	Green Island	67
B	622	Men and Boats	81
B	688	Milkfish	82
B	510	Shoot the Net	91
D	263	Shrimp Fisherman	97
B	543	Tilapia	106
C	538	Trees to Trade	109

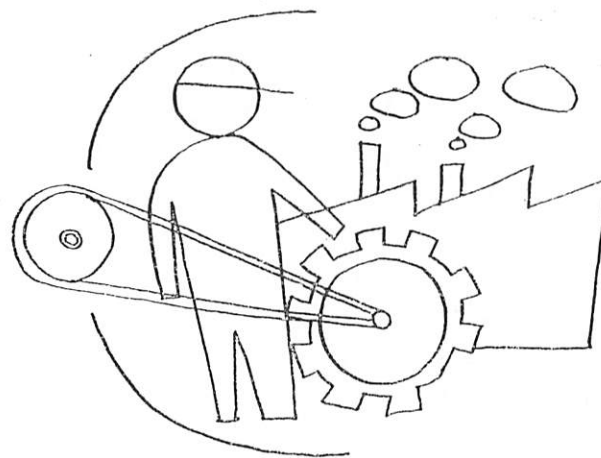

INDUSTRY AND LABOR

B	601	Americans At Work: Glassworkers	48
B	612	Americans At Work: Potters	48
C	008	American Factory	48
B	594	Americans At Work: Bookbinders	48
C	578	Beyond the Valley	52
C	614	Big Change in World Markets	52
B	654	Building for Labor	55
B	829	Building for Tomorrow	55
C	724	The Copper Story	57
B	374	Duck Feathers	60
B	592	Earth's Great Treasure	61
B	823	Four Elements	64
C	398	Great New South	67
B	408	House of Squibb	71
A	752	Krystallos	75
B	792	Labor of Love	76

B	135	Making of Fine China	79
C	589	A Mighty Fine Union	82
C	717	More Than Mountains More Than Gold	82
D	826	My Friend the Enemy	82
B	220	Our Union at Work	86
B	661	Prospectus for Growth	92
C	528	Share in Tomorrow	97
B	523	Story of the National Labor Relations Board	100
C	584	Story of 32 B	100
B	518	Sulphur	101
C	348	This is Automation	104
B	290	To Greater Vision	106
B	288	Today's Chick	107
A	303	Unionism Arrives in Honduras	110
A	308	U. S. Labor Unites	111
B	314	The Versatile Soybean	111
C	800	To The Fair	116
B	781	World's Fair - New York	116

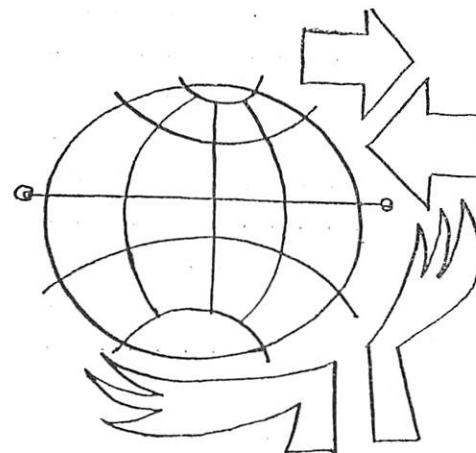

INTERNATIONAL RELATIONS

C	730	American Field Service Story	48
A	631	Berlin Story	52
C	578	Beyond the Valley	52
C	355	Birth of A Village	53
C	818	Bridge of Friendship and Faith	54
B	356	Brotherhood Operation	54
B	294	Building A New India	55
B	721	Campus International	55
B	373	Dawn Over Camau	58
A	670	Day of Denial	58
B	857	A Distant Province	60
B	592	Earth's Great Treasure	61
A	072	The Etawah Story	61
A	757	Evil Wind Out	62

B	695	Forging the Alliance	64
A	083	Formosa Story	64
B	381	A Friend in Need	65
B	087	Friend of the Worker	65
B	599	Friendship Link	65
A	088	The Frontier	66
A	395	Glorious Family	66
D	396	Guard This Above All	67
A	845	Hands of A Stranger	68
D	101	Himalayan Awakening - Nepal	69
A	110	India Plows Deeper	72
B	733	Invitation to India	73
B	734	Invitation to Pakistan	73
B	731	Island of Promise	73
B	795	Laredo to Panama	76
B	433	Let Us Live	77
A	758	Letter from Colombia	77
A	131	The Locust	78
A	848	The Longer Journey	79
A	744	A Nation Chooses	83
C	813	The Night of the Dragon	84
B	828	One Small Candle	85
B	849	The Other War	86
C	609	Partners for Peace	86
C	494	People and Petroleum	87
B	475	People Win Through	87
B	231	Philippine Progress	88
B	235	Planning for Plenty	89
C	712	Project Hope	92

B	661	Prospectus for Growth	92
C	252	The Road of a Hundred Days	94
A	759	School in Rincon Santo	96
B	801	Shield of Progress	97
B	677	SEATO to Safeguard for Freedom	98
A	702	Spotlight on Vietnam	98
B	271	Story of Koula	100
B	659	The Task Begun	102
A	671	They Are Not Alone	104
B	282	They Need Not Die	104
B	283	This Is My Philippines	104
B	542	A Ticket to Manila	105
B	847	To Begin Again	106
A	630	To Those Who Choose Freedom	107
C	825	Tomorrow in Their Hands	107
B	296	Training Men for the Atomic Age	108
B	780	Troubled Harvest	109
A	629	Unhappy Island	109
C	762	United in Progress	110
C	841	Vietnam: The Other War	111
B	321	We Build A Town	113



JOURNALISM

C	025	Assignment: Mankind	51
B	058	Country Editor	57
A	439	Loan of A Caldron	78
B	803	The President and the Press	90
A	629	The Unhappy Island	109

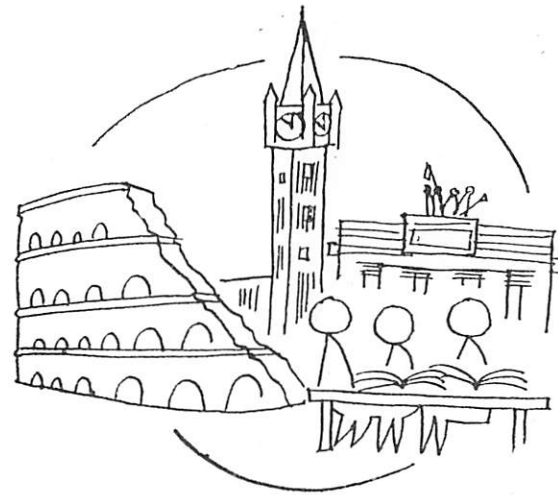

LIBRARIES AND MUSEUMS

C	595	Books for All	53
A	625	Books for Everyone	53
B	095	The Greatest Treasure	67
C	416	The Impressionable Years	71
B	831	Lincoln Center: The Place and Idea	78
B	270	Storehouse of History - National Archives	99
A	707	Tutankhamen's Treasures	109
B	635	Winterthur - Adventure in the Past	115
B	331	Wonder House	115

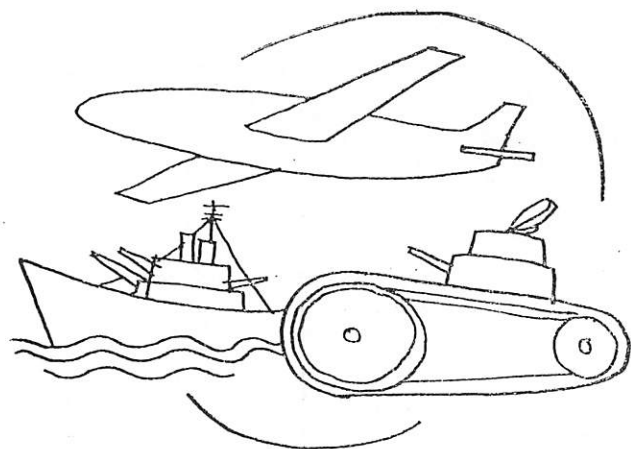

MILITARY

C 581 Dew Line Story.....60
 C 837 How To Fight A Guerrilla War.....71
 B 789 In Common Cause72
 A 153 Nautilus Crosses the Top of the World83
 C 813 Night of the Dragon84
 C 609 Partners for Peace86
 A 786 Profile of Power91
 B 677 SEATO Safeguard for Freedom98
 B 782 To Keep the Peace.....106

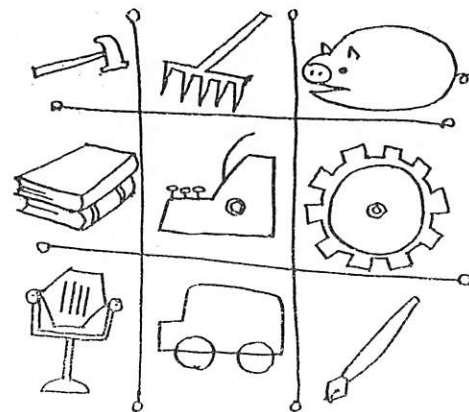

OCCUPATIONS

C 742 Agriculture USA47
 B 594 Americans At Work: Bookbinder48
 B 601 Americans At Work: Glassworkers48
 B 612 Americans At Work: Potters48
 A 775 I Hear the Carpenter Singing71
 A 752 Krystallos75
 C 458 Not by Chance85
 C 844 The Road Ahead94
 A 776 Student Engineer100
 A 799 Student Teacher100

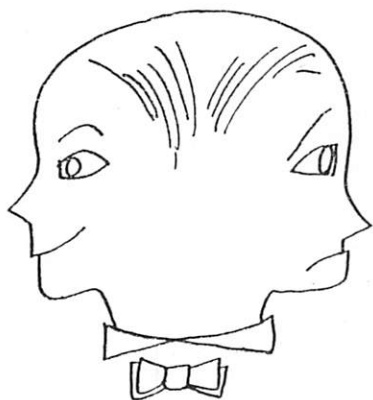

PERSONALITIES

C 012 And Now Miguel49
 A 580 Charley Russell's Friends56
 B 808 The Day of the Oath59
 C 779 Dependable Hands59
 B 127 Life of President Eisenhower77
 B 642 Election of John F. Kennedy61
 B 753 Emma Belle Sweet61
 C 076 The Face of Lincoln62
 B 812 From the Land of Lincoln: Adlai Stevenson66
 C 277 Helen Keller and Her Story69
 A 682 Hour of Challenge70
 B 603 In Search of Lincoln72
 B 645 The Inauguration of John F. Kennedy72
 C 738 The John Glenn Story74
 B 822 The Journey75
 C 437 Leave Evil for Good77
 B 684 Man of Progress: The De Forest Story80

B 678 The Peace Maker.....87
 B 768 The President90
 C 756 Profile - Gordon Cooper.....91
 C 686 Robert Frost94
 B 659 The Task Begun.....102
 B 001 Theodore Roosevelt, American104
 C 713 A Tour of the White House with Mrs. J. Kennedy...107
 C 613 Toward Tomorrow108
 C 328 Woodrow Wilson - Spokesman for Tomorrow115
 C 785 Years of Lightning, Day of Drums117
 D 339 The Yukawa Story117

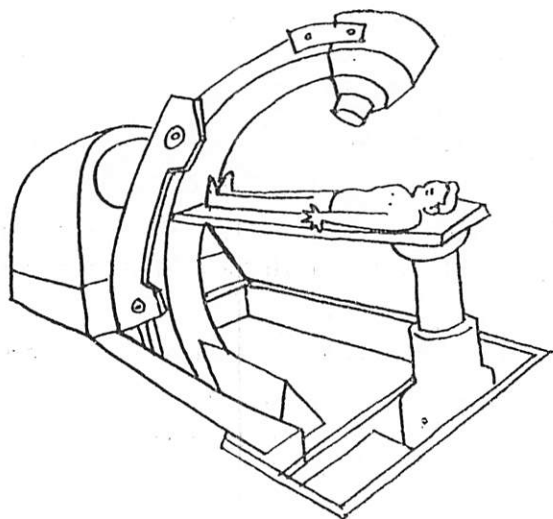

PUBLIC HEALTH AND WELFARE

B	014	Another Light	49
B	616	Beyond Silence	52
B	793	Born A Man	54
B	654	Building for Labor	55
A	365	Clean Water	56
A	366	Cleanliness Brings Health	56
✓ C	064	Dark Interlude	58
B	371	Defense Against Invasion	59
A	757	Evil Wind Out	62
A	377	Eyes and Their Care	62
A	708	Fresh Water from the Sea	65
B	414	Health and Happiness	69
A	407	Hookworm	69

B	408	House of Squibb	71
A	409	How Disease Travels	71
A	411	Human Body	71
A	418	Infant Care	72
A	420	Insects as Carriers of Diseases	73
A	798	"Joe"	74
B	136	Malaria Eradication	80
B	138	Man Learns to Heal	80
B	448	Man -- Maker of Abundance	80
B	142	Medicine	81
A	815	Men Who Care	81
B	159	New York Water Supply	84
C	478	A Place in the Sun	89
D	489	Public Health Nurse	92
A	502	Rehabilitation of the Blind	93
A	759	School At Rincon Santo	96
A	665	Tde Sink	98
B	521	Story of a Town	99
A	664	Stove and White Wash	100
B	282	They Need Not Die	104
C	285	Three of our Children	105
A	539	Tuberculosis	109
✓ A	554	Water, Friend or Enemy?	112
✓ A	561	Winged Scourge	115
C	672	With Hand and Heart	115



RELIGION

A 375 Easter in the U. S.61
 B 822 The Journey75
 B 451 The Nativity83

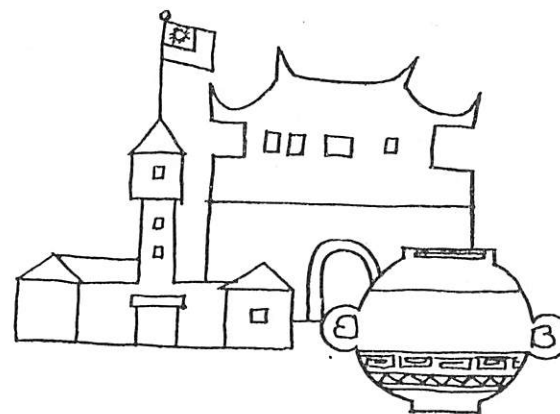

REPUBLIC OF CHINA

A 033 Formosa Story64
 B 394 Green Island67
 B 430 Kinmen (Quemoy)75
 C 704 Lee Yu's 4-H Banner77
 B 507 Reunion Bridge94
 C 833 Sinews of Freedom98
 B 714 Story of Li Li Chu.....100
 B 547 This Is Quemoy104
 B 741 Three Thousand Years of Chinese Art105
 A 689 Thunder Tiger Team105
 B 558 When the Communists Came114
 C 643 The Wu Family116

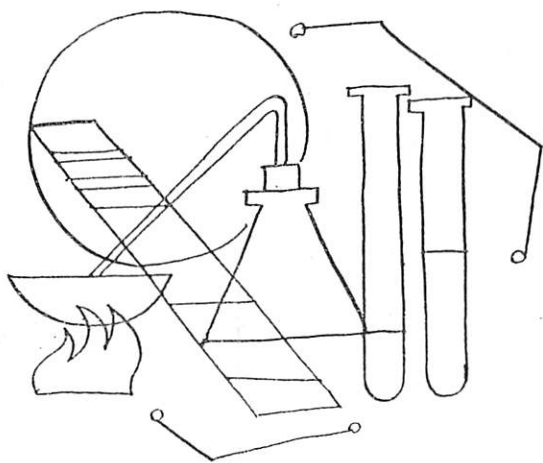

SCIENCE

B 586 Antarctica49
 C 706 Blueprint for Discovery53
 C 598 Coast Guard Cutters Around the Continent57
 B 811 Destination Man60
 C 606 Exploring by Satellite62
 B 823 The Four Elements64
 A 708 Fresh Water from the Sea65
 B 597 Handful of Soil68
 A 411 Human Body71
 B 113 Introducing the Atom73
 B 122 Killing Weed with 2, 4-D75
 B 596 The Little Giant78
 A 133 The Magnetic Bottle79
 B 142 Medicine81
 A 153 Nautilus Crosses the Top of the World83

B 715 Nutrition85
 B 466 Origin of the Motion Picture85
 B 692 Pacific Venture86
 C 230 The Petrified River88
 C 766 Power for Continent Seven90
 B 487 Principles of Electricity90
 B 525 Scientific Advancement96
 C 765 Story of Camp Century99
 A 516 Story of Doctor Jenner100
 B 518 Sulphur101
 B 649 Survey of Astronautics101
 C 700 Tenth Pacific Science Congress103
 C 348 This Automation104
 B 286 Time106
 B 290 To Greater Vision106
 B 314 The Versatile Soybean111
 C 650 X-15116

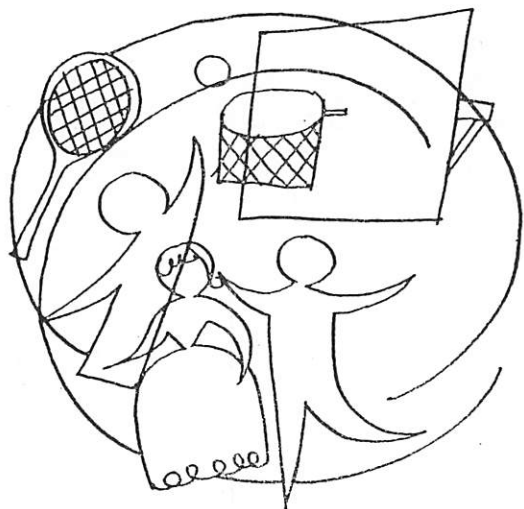

SPORTS AND RECREATION

A	385	Foreign Sports in the U. S.	64
B	084	Free Horizons	65
B	382	Fundamentals of Tennis.....	66
A	126	Libyan American Rodeo.....	77
B	769	Making of a Champ.....	79
C	480	Play Championship Basketball.....	89
B	481	Play Volley Ball	89
A	508	Sea Lions Baseball Team	97
C	024	Second Asian Games	97
A	511	Softball for Boys	98
A	091	Tennis Champion Althea Gibson	103
A	529	Thailand - Land of Athletes	103
C	555	Ways of a Field Champion.....	113
A	655	Wilma Rudolph - Olympic Star.....	114
B	337	Yellowstone National Park	117

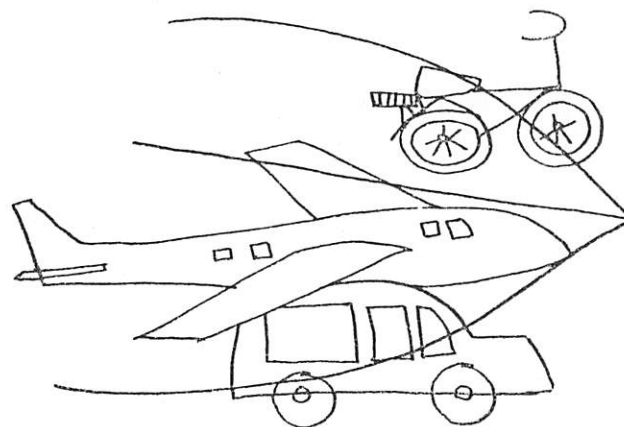

TRANSPORTATION

B	795	Laredo to Panama	76
A	153	Nautilus Crosses the Top of the World	83
B	617	Nuclear Ship Savannah	85
B	839	Transportation USA	109

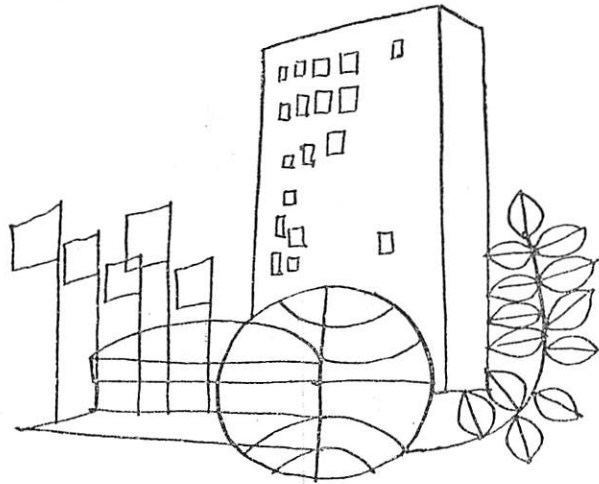

UNITED NATIONS

A 682 Hour of Challenge70
 B 678 Peace Maker87
 B 822 The Journey75

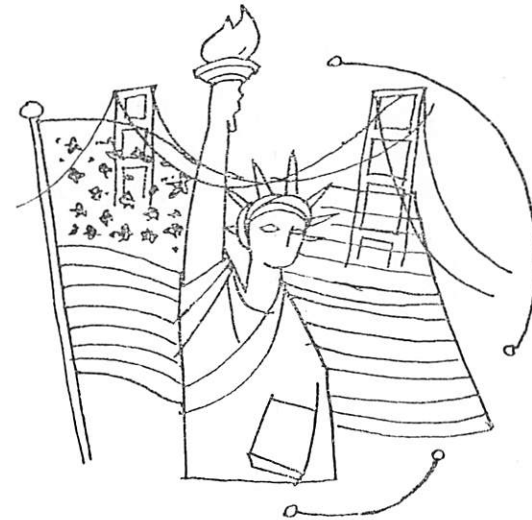

UNITED STATES

B 276 Alaska, 49th State47
 B 573 Alaska, Newest of USA47
 D 611 All About New York47
 C 614 Big Change in World Markets52
 C 834 California55
 B 836 Celebration55
 C 051 Coast to Coast57
 B 808 Day of the Oath59
 B 809 Face of America62
 C 690 Follow the Sun63
 C 720 Frontiers66
 C 398 The Great New South67
 B 607 Hawaii - U. S. A.69
 C 767 Highway Holiday69

C	644	A House Divided	70
B	642	The Election of John F. Kennedy	61
B	645	The Inauguration of John F. Kennedy	72
A	806	Independence Day: USA	72
B	816	It Is Right	74
C	438	Law of the Land	76
C	770	The March	80
C	717	More Than Mountains More Than Gold	82
C	683	A Nation Rises	83
C	151	A Nation Sets Its Course	83
C	583	New England Portrait	83
C	157	New World	84
B	787	New York	84
D	004	1964 Convention	85
B	226	Pattern for Peace	86
B	229	People of the Western Shore	87
C	234	Pilgrimage of Liberty	88
B	572	Portrait of a City	89
B	768	The President	90
C	838	President's Country	90
A	244	Problems of A Small Town	91
B	797	Quest for Freedom	92
A	251	R. F. D. (Rural Free Delivery)	95
B	269	The States and the Nation	98
B	847	To Begin Again	106
C	289	To Freedom	106
C	292	Tom Schular, Cobbler-Statesman	107
A	297	Transatlantic	108
B	305	The United States Today	110

C	713	Tour of the White House with Mrs. Kennedy	107
D	307	U. S. A.	110
C	835	A Visit to Washington With Mrs. LBJ	112
A	788	We Shall Overcome	113
C	322	Welcome to Washington	113
B	830	Wealth of a Nation	113
B	675	White House Past And Present	114



WOMEN

B 753 Emma Belle Sweet61
 C 277 Helen Keller and her Story69
 C 124 Lady from Philadelphia76
 C 141 Marian Anderson80
 A 091 Tennis Champion Althea Gibson103



YOUTH

C 730 American Field Service Story48
 B 721 Campus International55
 C 784 Higher and Wider69
 C 680 Men Enough for the Job81
 C 840 More Interesting People.....82
 B 679 A Mile High, A World Wide82
 C 746 Music in the Forest82
 B 461 The Open Road.....85
 C 681 Scout Trail.....96
 C 843 Still More Interesting People99



Alphabetical List of USIS Film

The films are listed alphabetically by title. The call number of each film is on the same line as the title, as is information on the film length, language, and whether it is in black and white or color.

The first film in the alphabetical list is A IS FOR ATOM. Its library number is B 340. Immediately following the title appears (E 15: C). This code indicates the film is available in English only, the film is 15 minutes long, and it is in color.

The second film in the alphabetical list is coded (E M 10: B). This means it is available in both English and Mandarin versions, runs 10 minutes, and the "B" means it is in black and white.

Some films will read E M A, which means they are available in English, Mandarin, and Amoy.

When requesting film, it is not necessary to list the title. The letter and call number to the left of the title are sufficient.

- B340 A IS FOR ATOM (E 15: C) (*)
An explanation for laymen of basic atomic principles through color animation.
- A802 ABOVE THE EARTH AND TO THE MOON (E M 10: B) (*)
Highlights of the Grissom-Young orbital flight and the Ranger IX moon shot.
- B007 AGRICULTURE, INDUSTRY AND POWER (E M 20: B) (*)
Covers research in uses of radio-active materials in agricultural and industrial production and power development. Stresses atomic energy potential for bettering economic standards of all nations.
- C742 AGRICULTURE USA (E M 30: C) (*)
Story of agriculture in the United States. The transition from limited agricultural production on individual farms to present-day achievements of mass production farming.
- B276 ALASKA, 49TH STATE (E M 20: C) (*)
The story of one of the newest American states.
- B573 ALASKA, NEWEST OF USA (E M 20: B) (*)
An American president signs the bill granting statehood to the territory of Alaska. The film presents general information and background material on Alaska.
- D611 ALL ABOUT NEW YORK (E M 35: C) (*)
Shows New York State -- its people, agriculture and industries, cultural aspects and scenic beauty.
- B732 AMERICA - EUROPE - AMERICA (Telstar 2) (E M A 15: B) (*)
Report on the first exchange of live television prog-

rams across the Atlantic ocean utilizing the Telstar communications satellite. The principle of the Telstar satellite and plans for related developments also are described.

C008 AMERICAN FACTORY (E M A 25: B)

Photographed in and around the General Electric factory at Appliance Park, near Louisville, Kentucky, the film describes the manufacture of refrigerators by automation and illustrates basic concepts of American industry.

C730 AMERICAN FIELD SERVICE STORY (E M 30: C)

International Scholarship Program of the AFS. Depicts experiences of a Sardinian boy in the United States and those of an American girl in Sardinia.

B594 AMERICANS AT WORK: BOOKBINDER (E M 13: B)

Describes the making of books from cutting and folding through stitching, trimming, compressing and application of the covers.

B601 AMERICANS AT WORK: GLASSWORKERS (E M 13: B)

Various phases of modern glassmaking are described from the mixing of raw materials to the automatic packaging of the finished product in mass production.

B612 AMERICANS AT WORK: POTTERS (E M 13: B)

This union-produced film shows skilled workers and artists engaged in the mass production of pottery in a \$3 billion American industry. Emphasis is placed on the part the industry plays in America's free enterprise system, and the interdependence of the potter's art with allied crafts.

D827 AMERICAN VISION (E M 40: C)

This film describes, in chronological order, paintings by American artists of the late 19th to early 20th century.

C012 AND NOW MIGUEL (M A 60: B)

Family tradition is sheep ranching; centers around small boy's ambition to become herder; how he learns responsibility, respect for tradition, pride in performing duty. Also portrays sheep ranching methods. Filmed in northern New Mexico.

B014 ANOTHER LIGHT (E 20: B)

How citizens of an American town acquire a new hospital through community efforts. Modern preventive medicine features of hospital and clinic and facilities for handling emergencies.

B586 ANTARCTICA (E M A 20: B)

Records historic Antarctic expeditions and explorations made by various nations. Early film footage and drawings and engravings from early newspapers are used to depict the role of the United States and other nations in these endeavors.

B015 ANTIOCH COLLEGE (E 20: B)

Portrays education in an unusual American college where students learn by alternating theory and experience.

B814 ARCHITECTURE USA (E 12: C)

Shows representative American architecture. Both traditional and modern structures reflect the American way of life.

C696 ART HERITAGE (E M 30: C)

Presentation of works of art in the Metropolitan Museum of Art, New York City. The collection symbolizing man's creative life through the ages is an inheritance providing knowledge of past cultures and showing influence on man's development.

C590 ART IN THE WESTERN WORLD (E M 30: C)

A descriptive presentation of art treasures from the National Gallery of Art representing each major epoch from the Byzantine to the present tells the story of the development of Western art.

台灣 B729 ART OF CHINESE PAINTING (E M A 20: C)

A study of Taiwan artist Huang Chun-pi as he paints in the traditional manner of Chinese artists.

中國 B621 ART OF LEE HSIANG-FEN (E M 17: C)

Miss Lee Hsiang-fen is not an actress in the ordinary sense of the word. Her acting follows the art of the traditional Peiping opera. She started her study of opera on the China mainland under the tutorship of the most famous contemporary Peiping opera artist-Mei Lan-fang. Since she found that her expression for development in the art she loved was being stifled, she fled from the Red Chinese Regime. In this picture, three selections chosen by Miss Lee are a sword dance called "Red Thread Steals the Jewel Box", an excerpt from the "Drunken Beauty", and a scarf dance entitled "The Dance of the Heavenly Maiden".

B588 ART OF THE MAYA (E 13: C) 77777

Exhibition of Maya art at the Detroit Institute of Arts -original works of art, sculpture in stone and terracotta, decorated pottery, carved jade, marble, clay figurines and ceramics. Major portion loaned by the National Museum of Guatemala.

B846 ART SCENE USA (E 17 C)

A look at the painting, sculpture and dancing being done in the United States today, by many of its best-known artists.

B023 ASIAN ARTISTS IN CRYSTAL (E M A 20: B) 37777

Includes 36 pieces of American crystal designed and engraved from original drawings by leading contemporary artists of 16 Asian and Middle East nations. Describes folklore, religious traditions and local customs.

C025 ASSIGNMENT: MANKIND (E M 28: C)

Story of complex and challenging job of getting out an international daily newspaper, the ideal that inspires the Christian Science Monitor, the people who are responsible for its operations. In addition to activities of each branch of operation in Boston, the film presents a round-the-world survey of Monitor correspondents at work.

B751 ATOMIC WEATHERMAN (E 18: C) 7777

Story of the world's first radioisotope-powered weather station at a remote site in the Canadian Arctic.

C749 ATOMS FOR SPACE (E 29: C)

Development and use of compact nuclear power sources for space -- two basic concepts are shown.

- C253 ARTUR RUBINSTEIN, NO. 101 (E M 25: B)
 Depicts the artist in the recording studio and his home, where he plays the following piano solos: Mendelssohn's "Spinning Song", Liszt's "Liebestraum", Chopin's "Waltz in C Sharp and "Polonaise in A".
- A743 BASIC PRINCIPLES OF A POWER REACTOR (E 10: C)
 A basic film to enable general audiences to understand nuclear power reactors and explain how various power reactors produce steam for the generation of electricity.
- B855 BEHIND THE SPACEMAN (E M 15: C)
 This is the often untold story of the tens of thousands of scientists, technicians, and workers of all kinds whose combined efforts make possible the American space program. Their efforts will culminate, in project Apollo, with the landing of American spacemen on the surface of the moon.
- A631 BERLIN STORY (E M 10: B) E
 The problems of Berlin, Germany, and how the Communists try to make life more difficult.
- B616 BEYOND SILENCE (E 20: B)
 Story of Gallaudet College, a school for the deaf, and the work of the Gallaudet Graduate School, a world famous research center for the deaf.
- C578 BEYOND THE VALLEY (E M 30: C)
7514
H17 Describes the industrial development of Puerto Rico through private investment and government cooperation.
- C614 BIG CHANGE IN WORLD MARKETS (E M 30: C)
 Survey of post-war economic progress in the free world. The emphasis is on productivity and increased purchasing power of the average worker family.

- C355 BIRTH OF A VILLAGE (E 25: B) 7174
 Thousands of refugees fled to South Vietnam from North Vietnam on American ships. They built a new village with American help. America sent medical teams, agricultural experts, food and other necessities to the area.
- C357 BLESSINGS OF ATOMIC ENERGY (E M A 30: B) E
 A survey of Japanese accomplishments in atomic energy research.
- C706 BLUEPRINT FOR DISCOVERY (E 30: C)
 Record of an experiment conducted under the guidance of the National Science Foundation and the feasibility of drilling into the earth's crust from an ocean platform to obtain samples of sedimentary layers beneath the ocean.
- C595 BOOKS FOR ALL (E M 30: C)
 The role in the community of a small-town public library.
- A625 BOOKS FOR EVERYONE (E 10: B)
 Pocket edition books, both popular and classical, can now be purchased almost everywhere. This film shows how modern printing methods have made reasonably priced good books available to everyone.
- B360 BORAX (M 20: B)
 Atomic research experiments. Describes preliminary experimental work and the construction and operation of a boiling water power reactor. Practical results are shown through the lighting of the city of Arco, Idaho, by nuclear power from an experimental plant known as Borax.

B793 BORN A MAN (E 20: B)

A documentary account of the rehabilitation of a blind electrician.

D694 BOSTON SYMPHONY ORCHESTRA (E 40: B)

日本
The Boston Symphony Orchestra in Japan - performances of works by American contemporary composers (Blackwood and Copland) as well as music by Berlioz and Debussy.

C818 BRIDGE OF FRIENDSHIP AND FAITH (E M 25: C)

韓国
This production documents the state visit to the United States of President Chung Hee Park of Korea. During his stay in the United States, he visits New York where he participates in "Korea Day" at the World's Fair. He is also seen at the U.S. Military Academy at West Point and at Cape Kennedy where he witnesses the launching of a space vehicle.

B794 BRIDGE TO TOMORROW (E 18: B)

The integration of the humanities into the courses of science and technology students at Massachusetts Institute of Technology.

B354 BRIDGING THE GOLDEN GATE (E 14: B)

Erection of a suspension bridge across the entrance to the San Francisco harbor. Shows engineering precision, machine operations and skilled workmanship.

B356 BROTHERHOOD OPERATION (E 20: B)

南
71)C
Shows the work of doctors, nurses and social workers from the Philippines in ameliorating the living conditions of refugees in South Vietnam under "Operation Brotherhood".

B294 BUILDING A NEW INDIA (E 15: B)

イ=ト
Portrays the work of the Indian Government in trying to solve its food crisis.

C633 BUILDING A NEW WORLD (E M 30: B)

Shows the development of American architecture from the time of the first settlers to the present day. The historical background of the nation is revealed through the evolution of its architecture.

B654 BUILDING FOR LABOR (E 20: B)

Presentation of the headquarters building of the International Hod Carriers, Building and Common Laborers Union. Film shows the relationship of the laborer to various crafts, trades and construction skills.

B829 BUILDING FOR TOMORROW (E M 21: C)

This film shows the growth, modernization and improvement in tools, techniques and management of the construction industry.

C834 CALIFORNIA (E 31: C)

A description of the state of California -- its natural beauty, productive capacity, amusements, cultural attractions and educational facilities.

B721 CAMPUS INTERNATIONAL (E 20: C)

イ= ス=タ=シ
7=2=7
モ=ハ
韓国
The foreign student program at the University of Arizona. Students depicted in the film represent Iran, Sudan, Denmark, Cuba and Korea.

B836 CELEBRATION (E M 20: C)

中国
イタリ
The film shows Chinese and Italian celebrations in America, and how they have become a part of the American scene.

- C674 CENTER OF LEARNING (E M 30: C)
Presents six educational centers which are representative of the various types of universities in the United States.
- A580 CHARLEY RUSSELL'S FRIENDS (E 10: C)
Through the internationally famous American cowboy-artist's paintings of the West as he knew and loved it, are revealed the man and the artist, and the people who were his friends.
- B002 CHESAPEAKE (E 15: C)
The story of oyster fishermen in the Chesapeake Bay. The fishermen, from Cambridge, Maryland, use sailboats and are part of a shrinking industry on the American east coast.
- A691 CHINESE ART TREASURES (E M 10: C)
Exhibition of Chinese Art Treasures from the Court Collection now housed at the Palace Museum in Taiwan.
- A365 CLEAN WATER (M 10: C)
Importance of natural waterways; dangers of pollution to fish, wildlife; to city supply systems, recreational facilities and public health. Made in cooperation with the United States Public Health Service.
- A366 CLEANLINESS BRINGS HEALTH (M 9: C)
Health and personal cleanliness of a happy, healthy family contrasted with those of a sick, careless family; how simple sanitary precautions and personal hygiene keep a family healthy and how careless habits cause illness in other families.

- C598 COAST GUARD CUTTERS AROUND THE CONTINENT (E M 30: C)
Three U. S. Coast Guard cutters make an historic trip establishing the first west-to-east surface passage of the Arctic reaches of the North American continent.
- C051 COAST TO COAST (E M 30: B)
Opening sequences relate earlier history of the American westward movement. As eastern cities develop culturally and commercially, an increasing number of pioneers make a difficult westward journey. Film outlines areas opened to settlement in Northwest Territory and through Louisiana Purchase; influence of frontier life on development of American character.
- C736 CONCERT TOUR - U.S.A. (E 30: C)
A tour of musical America filming the performances of famous vocalists and instrumentalists in widely diverse areas of the United States and serving to demonstrate that the best in music is being brought to small towns and cities as well as to metropolitan areas.
- C724 COPPER STORY (E 30: C)
The mining, smelting and refining of copper and the manufacture of finished products.
- B058 COUNTRY EDITOR (E M 20: B)
Depicts the daily activities of a small town editor. Film stresses traditional spirit of integrity and public service of free press; supports theme of freedom of expression.

C060 CREATIVE ART IN RURAL AMERICA (M 30: B)
The arts of rural workers, farmers and the farm wives in Wisconsin.

1-17
F-17
C062 DANCE TO FREEDOM (E M 30: B)
Documents the escape from East to West Berlin of two top-ranking Hungarian ballet dancers. They explain why they left their native Hungary. Shows many ballet sequences.

C064 DARK INTERLUDE (E M 30: B)
The physical and psychological adjustment to a life of blindness by a young man who has recently lost his sight. At the Overlook School for the Blind he achieves emotional security, social competence, and the ability to meet the demands made of the average well-adjusted person.

7-17
C640 DARTMOUTH VISITED (E 30: C)
Describes life at Dartmouth, including academic facilities and extra-curricular activities.

3-17
B373 DAWN OVER CAMAU (E 17: B)
This is a story of refugees from North Vietnam who build a new village with help from the United States. They have chosen freedom rather than live under Communist-controlled North Vietnam.

F-17
A670 DAY OF DENIAL (E M 10: B)
Film covers closing of the Berlin border, raising of barricades, refugees, reaction of people of Berlin and the firm stand taken by the United States in guaranteeing the rights of free Berlin.

B808 DAY OF THE OATH (E M 20: C)
Going beyond the strictly topical and reportorial approach, this film uses the occasion of President Johnson's Inauguration to convey a sense of strength, stability and continuity in the United States Government. Particularly interesting in this connection is the use of motion picture footage of presidential inaugurations beginning with President McKinley, the first ever recorded on film. The film contains colorful sequences of the inaugural parade and highlights of inaugural week festivities and traditions associated with Presidential inaugurations.

D817 DAY ON AN AMERICAN FARM (E 40: C)
Shows the operation of a 300-acre dairy farm as a successful American family enterprise.

B371 DEFENSE AGAINST INVASION (M 13: C)
Value of immunization against disease explained in dramatic story.

A065 DEFENSIVE SKY POWER (E M A 10: B)
U. S. missile research and development. The launching of various missiles is shown accompanied by an account of the potentialities and actual achievements of the missiles tested.

C779 DEPENDABLE HANDS (M 28: C)
Story of the growth and development, in average American families, in different regions of the US., of four flight crew members--First officer, Stewardess, Flight Engineer and Pilot.

B698 DESIGN FOR MUSIC (E 15: C)
This film shows the research and preparation for the design of New York's Lincoln Center for Performing Arts. Conductor Leonard Bernstein, who narrates the film, also conducts an orchestral selection.

B811 DESTINATION MAN (E M 18: C)
Describes the results of research in aerospace medicine undertaken by American space scientists.

C581 DEW LINE STORY (E M 28: C)
Construction of the Distant Early Warning radar system north of the Arctic Circle.

Việt Nam
B857 A DISTANT PROVINCE (E M 13: B)
Shows the daily work of an AID representative in a remote Vietnamese village: he talks to villagers about their problems; works with the provincial governor, the local police chief, and American military to help provide food, shelter and protection.

中國
B067 DONG KINGMAN (E M 20: C)
Chinese-American artist Dong Kingman paints scenes in New York City's Chinatown. Artist prepares rough sketch, completes canvas at home. Scenes of artist's family apartment. Other paintings shown, revealing modern, Oriental influences. Emphasis on success of this foreign-born artist and his contribution to American cultural life.

Việt Nam
B374 DUCK FEATHERS (E M A 18: B)
A Vietnamese family grows ducks with government help.

B592 EARTH'S GREAT TREASURE (E M 20: B)
Thirteenth World Congress of the Junior Chamber of Commerce International held in Minneapolis, Minnesota.

A375 EASTER IN THE U. S. (E 10: B)
Depicts religious freedom in the United States through the story of Easter.

7/1/63
B038 EDUCATION FOR BETTER LIVING (E M A 20: B)
A pilot project bringing about closer relationships between school and community at the Philippine UNESCO Training Center in Bayambang, Pangasinan.

C575 EIGHTH SEA (E 30: B) The story behind the construction of the St. Lawrence Seaway - the deepening of the river channel, the building of the giant locks and construction of the dam to harness the hydroelectric power potential of the river.

B753 EMMA BELLE SWEET (E 15: B)
The story of a tribute to an American teacher, of her influence on one of her pupils, Dr. Ralph J. Bunche, and a national award to the teacher.

B642 ELECTION OF JOHN F. KENNEDY, U. S. PRESIDENT (E 20: B)
Highlights from the national conventions and pre-election campaigning of the Democratic and Republican candidates including footage on TV debates; concludes with the election of President John F. Kennedy.

1-6
A072 ETAWAH STORY (E 10: B)
Shows agricultural rehabilitation projects being conducted in the villages of the Etawah District through the Indian Government and ICA.

C821 EULOGY TO 5:02 (E M 26: C)

英国

An expression of freedom through a kaleidoscopic view of how people use it. To eulogize a forgotten minute of freedom, twenty worldwide stories without beginning or end, without historical significance, were recorded in twenty cities while the hands of Big Ben in London recorded 5:02, May 18, 1965.

A757 EVIL WIND OUT (E 10: B)

コロムビア

Shows how a doctor from the Colombian public service overcomes superstition in a backward village, and through health education and proper treatment is able to significantly reduce the infant mortality rate. Results in demand for a clinic which people of the village build, with assistance from the Colombian government, under the "Alliance for Progress."

C606 EXPLORING BY SATELLITE (E M 30: C)

Describes the physical properties of a satellite, of the instruments, their performance and purpose.

A377 EYES AND THEIR CARE (E 11: B) Structure, functions disorders, hygiene of the human eye; defects, and their correction. Rudimentary rules for care of eyes.

C076 FACE OF LINCOLN (E M A 30: B)

Dr. Merrill Gage, a leading American sculptor, re-creates the facial image of Abraham Lincoln as he talks informally of events which were reflected in Lincoln's face.

B809 FACES OF AMERICA (E 20: C)

Colorful images of America are representative of all facets of U. S. society.

B380 FAMILY OF MAN (E M A 20: B)

Photographer Edward Steichen explains his collection of pictures which are assembled to show the essential oneness and goodness of mankind. Steichen, brother-in-law of poet Carl Sandberg, is called the dean of American photography.

A651 FIDDLER'S FESTIVAL (E 10: B)

Performances of musicians participating in an annual festival of folk and modern music held in Berryville, Va.

A662 FIFTEEN DAYS IN SPACE (E M 10: B)

American space developments including the Tiros and Midas satellites as well as Virgil Grissom's sub-orbital flight of July 21, 1961.

C727 THE FIRST HUNDRED YEARS (E 30: C)

Growth, development, activities and achievements of Howard University in Washington, D. C.

B810 THE FLIGHT OF GEMINI 4 (E M 12: C)

Highlights the space mission of James McDivitt and Edward White from countdown, June 3, 1965, through 62 orbits, recovery, and President Johnson's welcome to the astronauts and their families. The 20 minute "walk" in space by astronaut White as he talks with Captain McDivitt, who communicates directly with ground control, is also shown in this Agency-produced documentary film.

C690 FOLLOW THE SUN (E M 30: C)

The United States through the eyes of a visiting journalist -- its industry, agriculture, conservation, natural resources and people.

A385 FOREIGN SPORTS IN THE U. S. (M 10: B)

A brief history of the background of present day American sports. The film relates what countries the described sports came from, and how the games have changed over the years.

B695 FORGING THE ALLIANCE (E 16: C)

Covers the Dec. 1961 visit by President and Mrs. Kennedy to Colombia and Venezuela.

A083 FORMOSA STORY (M A 10: B)

Explains the important aspects of relations between the United States and the Chinese Nationalist Government. People of Taiwan witness and participate in a cooperative program extended by JCRR and MSA making the island more secure and advancing it toward self support.

B823 FOUR ELEMENTS (E M 12: C)

The film describes the conversion and combination of the traditional Greek elements (earth, air, fire and water) into manufactured goods as an illustration of America's productive ability. We see a hydroelectric dam and power station in Nevada where waterpower is converted into electricity; an automated coal mine in Virginia; coke and steel furnaces in Pennsylvania Texas oil fields, and a California oil refinery. The film then shows the combination of various raw materials into a fibre filament which is spun and woven into fabric. Man's well-being depends on how well he can use the wealth of the earth, air, fire and water.

B084 FREE HORIZONS (E M 20: B)

National parks in the United States and their facilities for enjoyment by travelers and vacationists.

A708 FRESH WATER FROM THE SEA (E M 10: B)

The U. S. Government's saline water conversion program - two methods of transforming sea water into fresh water.

B381 A FRIEND IN NEED (E 15: B)

This film shows the aid given to the people of Vietnam by the people of the U. S. and the Philippines. It stresses that with help the people of Vietnam can rebuild their country. Shows the arrival of Philippine officials who brought goods donated by the Red Cross and private sources, to help those who suffered from communist oppression.

B087 FRIEND OF THE WORKER (E 20: B)

The film is a satirical approach to Communism's claim to being a friend of labor. Centered around Berlin's crippling railroad strike of 1948, the film shows actual Soviet labor practices in East Germany, and contrasts conditions there with those in West Germany.

B599 FRIENDSHIP LINK (E M 20: B)

American and Thai families exchange their 18-year old sons for a year. The life and activities of each student in his foreign environment are depicted.

C718 FRIENDSHIP SEVEN (E M 57: C)

Reports in detail on the launching into orbit of the space craft Friendship Seven, piloted by the astronaut

John H. Glenn, Jr., of the United States Marine Corps. The film describes the entire project including the assistance of the ground-based co-pilots of Project Mercury, the Mercury Control Center itself making decisions and issuing commands, and the work of 18 tracking and telemetry stations on three continents.

B812 FROM THE LAND OF LINCOLN: ADLAI STEVENSON
(E M 17: B)

A memorial film, showing highlights of the public career of Ambassador Adlai E. Stevenson.

A088 THE FRONTIER (E 10: B)

A powerful and dramatically photographed film showing the devastating effect of the Communist decision to establish a no-man's-land between West Germany and Communist Germany and Czechoslovakia. The picture contrasts the modes of life on the boundary, pointing up the hopeful future of the West Germans and the desolation faced by those on the Communist side.

C720 FRONTIERS (E M 30: C)

Americana of the West as typified by the States of Utah and Idaho. Film covers the history, geography, industry, culture, sports and people of the area.

C382 FUNDAMENTALS OF TENNIS (E 22: B)

Basic tennis strokes (backhand, forehand, service, volley, half-volley) and strategy explained and illustrated by Don Budge.

A395 GLORIOUS FAMILY (E 10: B)

Cartoons show the adverse effects of Communism

on Chinese rural family life. A successful farmer and head of his family is left with nothing but a banner after the Communists in one way or another have convinced the family that it should give to the regime their livestock, rice, farm implements and land.

C398 THE GREAT NEW SOUTH (E 30: C)

Describes the industrialization of the South, showing how it is utilizing its natural resources and developing skilled labor to enable it to play a major role in the economy of the United States.

B095 THE GREATEST TREASURE (E M 20: B)

The story of the United States Library of Congress and its collection of information.

B394 GREEN ISLAND (E A 20: B)

Importance of proper management and cutting, reforestation and value of forests to the country's economy. Development of Taiwan's "Green Island" program is shown.

C668 GROWTH OF A LANGUAGE (E 30: B)

Utilizing live photography, art work, and animation, the film presents the historical development of American English against a background of the factors involved in language change and growth.

D396 GUARD THIS ABOVE ALL (E 40: B)

The history of the struggle of the Philippines to gain

their rights and liberties in a republican form of government; the story of Stalin University and how followers are trained to spread the doctrine of communism; the ways and means employed by communist advocates to persuade people and gain control of the government with the ultimate goal of forcing them to relinquish rights and liberties they have long fought for.

B597 HANDFUL OF SOIL (E 15: B)

Research in the development of antibiotics, and cooperation of scientists and pharmaceutical companies in the mass production of antibiotics.

A845 HANDS OF STRANGER (E 11; B)

Shows the struggle by the South Vietnamese, with American and other country social and economic assistance, to heal the wounds of war and to build a sound basis for a peaceful future. This film also tells of the extensive third country medical assistance program now going on in South Vietnam.

D400 HAPPY HARVEST (A 40: B)

Production and proper applications of chemical fertilizers over various agricultural crops results in abundant harvests.

B750 HARVEST OF AN ATOMIC AGE (E 15: C)

Demonstrates results of American experimental work with atomic irradiated seeds to develop stronger strains of plants.

C699 HARVEST OF LEARNING (E M 30: B)

The story of American land-grant colleges and universities including their unique character and contribution to the nation's educational system.

B607 HAWAII - U. S. A. (E M 20: C)

A basic film on Hawaii, its people and resources.

B414 HEALTH AND HAPPINESS (M A 20: B)

Importance of environmental sanitation measures. Certain simple rules bring health and happiness to the family.

C277 HELEN KELLER AND HER STORY (E M A 50: B)

Biography of Helen Keller, enacted by Miss Keller and narrated by Katherine Cornell. Highlights of her life from infancy to her 75th birthday.

C784 HIGHER AND WIDER (E M 27: C)

Activities of the 11th World Boy Scout Jamboree, held in Athens, Greece, in 1963.

C100 HIGHLAND WOODCARVER (E 30: B)

A farmer in the mountainous southeastern United States carries on traditions by carving in wood.

C767 HIGHWAY HOLIDAY (E 30: C)

Seeing America by car.

D101 HIMALAYAN AWAKENING (E M A 40: C)

Nepal in the 20th century - economic progress and planned development with Indian and American aid.

B405 HOG INDUSTRY (A 40: B)

Detailed coverage of hog production on Taiwan with assistance of JCRR. Emphasis on prevention of hog epidemics.

A407 HOOKWORM (M 11: C)

Careless Charlie is very sick from hookworms and cannot work his farm. When shown how hookworms breed in dirt, how they attack humans and how they are easily eradicated, Charlie becomes careful.

Animated cartoon.

C102 HOOVER DAM (E 30: B)

Hoover Dam, its construction and the benefits it has given to the people of southwestern United States, are described in this film. The picture shows how this multi-purpose dam prevents floods, irrigates arid areas, provides electricity to hundreds of communities including Los Angeles, and serves as a recreational and tourist attraction.

A682 HOUR OF CHALLENGE (E M 10: B)

Highlights of President Kennedy's address before the United Nations General Assembly in which he challenged the Soviet Union to a peace race - not an arms race.

A104 HOUSE (Music 10: C)

House is not a film on architecture but an experiment in the use of motion pictures as an art medium. No narration is used but the visual is accompanied by music especially written for the picture by the producers who are also the owners of this California house.

C644 A HOUSE DIVIDED (E M 30: B)

Dramatic footage supplied by the American motion picture industry, contemporary paintings and engravings and original photographs illustrate some of the concepts of freedom on which the U. S. was founded.

A brief summary of geographical expansion and economic growth of the nation follows and finally an explanation of the forces which split the North and South resulting in the Civil war.

B408 HOUSE OF SQUIBB (M 20; B)

Portrays the manufacture of medicine in one of America's large pharmaceutical houses.

A409 HOW DISEASE TRAVELS (M 12: C)

How polluted water, contact with ill persons and insect carriers spread disease. How disease can be stopped by sanitary measures, isolation of sick and other simple precautions.

C837 HOW TO FIGHT A GUERRILLA WAR (E 25: B)

Narrated by Walter Cronkite, the CBS documentary program describes the war in Malaya, and tells why it was not the same type of war that is being carried on in Viet Nam.

A411 HUMAN BODY (M 9: C)

Very simple study of the human body: bone structure, muscles, respiration, bloodstream, brain. Importance of care of body through well-balanced diet, fresh air, personal cleanliness.

A775 I HEAR THE CARPENTER SINGING (E M 10: B)

A young carpenter chooses his career.

B003 IDYLIC ISLAND (E 20: C)

A report on a three-day visit to Taiwan.

C416 THE IMPRESSIONABLE YEARS (E M 30: B)

Story of a little girl discovering the world of books. Contains natural humor, excellent photography and original music score. New York Public Library.

B789 IN COMMON CAUSE (E M 18: C)

Shows the U. S. S. Ricketts being operated by a multi-national crew. NATO countries represented: United States, Great Britain, Italy, Germany, The Netherlands, Greece and Turkey.

B603 IN SEARCH OF LINCOLN (E M 20: C)

The film takes the form of a visit to the sites that Lincoln knew in childhood and adult life before his election to the presidency. The purpose is to acquaint the viewer with American conceptions of Lincoln as a leader whose efforts on behalf of democracy and human values are of universal significance.

B645 INAUGURATION OF JFK, 35TH PRESIDENT
(E M A 20: C)

Highlights of the inauguration of John F. Kennedy.

A806 INDEPENDENCE DAY: U.S.A. (E M 10: C)

Describes the various ways Americans celebrate July 4th in honoring its national ideals of human rights and heroes responsible for the Declaration of Independence.

A110 INDIA PLOWS DEEPER (E 10: B)

A look at agriculture rehabilitation conducted by the Indian Government under a Five Year Improvement program.

A418 INFANT CARE (M 10: C)

Family with healthy children is expecting "Little Number Five". Wise mother observing proper diet, taking care of herself and baby while he is very young,

proper feeding after he begins to take solid food, visiting prenatal clinic, she helps make him strong and healthy.

A420 INSECTS AS CARRIERS OF DISEASES (M 10: C)

In an animated cartoon careless Charlie lives with flies, lice and mosquitoes until he learns how they make him sick; then becomes careful Charlie, applying simple methods of eradicating pests.

B113 INTRODUCING THE ATOM (E M A 20: B)

Provides basic explanation atom, atomic energy. Animated sequences Los Alamos; preparation, storage radioisotopes at Oak Ridge Atomic Apothecary. Touches on uses, stresses great potential atomic materials in medical research, agriculture, industry.

B733 INVITATION TO INDIA (E 20: C)

Covers Mrs. John F. Kennedy's March 1962 visit to India.

B734 INVITATION TO PAKISTAN (E 20: C)

Covers Mrs. John F. Kennedy's March 1962 visit to Pakistan.

B426 IRRIGATION FARMING (E M 20: B)

Irrigation by furrow and flooding methods; need for irrigation in certain sections of the United States; role of Boulder Dam in utilizing natural sources of water for irrigation.

B731 ISLAND OF PROMISE (E M 20: C)

Modernization of Puerto Rico through long-range planning and governmental and industrial assistance in the training of its citizens.

B816 IT IS RIGHT (E 12: C)

This film consists of selected portions of President Johnson's address to the Congress on March 15, 1965 in which he requested the enactment of legislation to strengthen and protect voting rights of Negro Americans.

C118 JASCHA HEIFETZ - 103 (E 25: B)

Glimpses of the artist's home life, his practice sessions, and the concert stage.

C119 JASCHA HEIFETZ - 104 (E 25: B)

Violinist Jascha Heifetz in an impromptu recital for students of Claremont College, Pomona, California. With his accompanist Emanuel Bay, he plays Mendelssohn's "Sweet Remembrance," Brahms' "Hungarian Dance," "Melody" by Gluck, "March" from Prokofiev's opera, "The Love for Three Oranges," Wieniawski's "Polonaise in D" and "Hors Staccato."

A798 "JOE" (E 10: B)

The story of a retired factory worker showing his contentment as a result of benefits received from Federal social security programs.

A703 JOHN GLENN ORBITS THE EARTH (E M A 10: B)

This film shows the minute-by-minute highlights of John Glenn's three orbits of the earth in "Friendship 7." Film also shows the blast-off preparations at Cape Kennedy, the ground support or monitoring stations around the world and the recovery of Glenn and his capsule at sea.

C738 THE JOHN GLENN STORY (E M 30 C)

Biographic sketch of astronaut John Glenn. In addition to his achievements in space the film describes his boyhood in a small community in the midwest.

B822 THE JOURNEY (E M 13: C)

This Agency documentary records the events of October 4, 1965 when Pope Paul VI visited the United States to appear before the United Nations in a plea for world peace.

B122 KILLING WEEDS (E 15: C)

How to use 2, 4-D (chemical weed killer) safely and effectively on wheat, rice, corn and other crops. Spraying techniques illustrated. Cautions against use of 2, 4-D in gardens.

B430 KINMEN (QUEMOY) (E M A 20: B)

Documents various aspects of agricultural economy on the offshore island. By working together, the people of Kinmen transform barren land into a cultivated area by utilizing modern farming techniques.

C772 KNOWLEDGE AND IDEAS (E 30: C)

The story of television's role in education.

A123 KOREAN ART MASTERPIECES (E 10: C)

A film presentation of Korea's National Collection of historic art treasures as displayed at the National Gallery of Art, Washington, D. C. A collection of religious sculpture and personal ornaments of the 5th and 7th Centuries.

A752 KRYSTALLOS (E 11: C)

Explains the history and use of quartz crystals in communications systems.

B792 LABOR OF LOVE (E 20: B)

Three young career employees in the performance of their duties as "Forest Ranger" in the National Park Service; "Social Worker" for the City of New York and "Physical Therapist" for the State of Connecticut.

C124 LADY FROM PHILADELPHIA (E 55: B)

東南
アジア
The late Edward R. Murrow's television program covering Marian Anderson's tour of Southeast Asia under the sponsorship of the Department of State.

B431 LAND TO THE TILLER (M A 40: B)

中国
Documents land reform in the Republic of China through 1953.

B795 LAREDO TO PANAMA (E 18: C)

Opening of inter-American highway from Laredo, Texas to Panama, resulting in improved economic conditions and better understanding through communications among surrounding areas.

C438 LAW OF THE LAND (E M 30: B)

Shows how, in a democratic society, ideas of ordinary citizens can become law of land. Demonstrates bicameral legislative procedure in the United States by showing steps new bill must pass through in order to obtain approval of both houses of Congress and be signed into law by the President.

B820 LEARNING TO EARN (E M 20: C)

Describes educational facilities provided by the Connecticut State Department of Education for the school population interested in vocational/technical training.

B127 LIFE OF PRESIDENT EISENHOWER (M A 20: B)

Film biography of former President Dwight D. Eisenhower.

C437 LEAVE EVIL FOR GOOD (E 40: B)

マレーシア
The film shows the transformation of a Communist guerrilla fighter to a loyal government worker in Malaya.

C704 LEE YU'S 4-H BANNER (M 30: C)

台湾
The film is a documentary of the 4-H movement on Taiwan. Story centers around farmboy Lee's participation in local 4-H activities.

B433 LET US LIVE (E M A 19: B)

ドイツ
Shows facilities in West Berlin for handling refugees from political oppression in East Germany and expediting transfer of refugees to points of resettlement in the free world.

A758 LETTER FROM COLOMBIA (E 10: B)

コロンビア
By showing progress being made in land reform, public housing and introduction of modern techniques, the film illustrates the growing awareness of the Colombian people to what they can do for themselves, with government assistance, under the "Alliance for Progress".

A126 LIBYAN AMERICAN RODEO (E 10: C)

リビア
Presentation of a "Wild West" rodeo through the efforts of members of the United States Air Force and the Libyan cavalry.

B435 LIFE FOR THE LAND (E 20: B)

インド
Explains the use of fertilizers to increase agricultural productivity in India.

- B831 LINCOLN CENTER: THE PLACE AND IDEA.
(E M 15: C)
An outline of the growth of the complex of buildings comprising the Lincoln Center for the Performing Arts in New York City.
- B596 THE LITTLE GIANT (E M 20: B)
Description of the transistor, its development and uses.
- C842 LIVE VIA EARLY BIRD (E 30 C)
A record of the performance of the first trans-ocean satellite ever to maintain constant, 24-hour communication between two continents while in orbit.
- B610 LIVING WITH THE ATOM (E M 18: C)
Intended to reassure communities in which atomic installations are located, the film explains safety devices for the protection of workers and the community and at the same time shows how atomic energy fits into the pattern of evolution for the benefit of mankind.
- A439 LOAN OF A CALDRON (E 10: C)
Shows the consequences of believing preposterous statements that have no basis in fact. The Hoja demonstrates for the villagers that accepting unsubstantiated reports and rumors unfavorable to their own government can create an unreal world, and prejudices in which they become an easy prey to unfriendly influences.
- A131 THE LOCUST (M 10: B)
The United States helps Iran fight a plague of locusts.

- A848 THE LONGER JOURNEY (E 10: C)
The highlights of the 1966 Seven-Nation Manila Conference are examined as the participants meet to search for a way toward peace.
- C824 LOOK NORTH (E 28: C)
This film describes the academic and research facilities available on the far-flung campus of the University of Alaska.
- B440 LOS BANOS STORY (E 20: C)
The Los Banos College of Agriculture shows practical farming ideas and research undertaken by the school.
- C790 LUNAR BRIDGEHEAD (E 30: B)
A detailed account of the performance of the moon shot launched in July, 1964.
- A133 MAGNETIC BOTTLE (E 10: C)
Research efforts to attain and control a fusion process for the development of unlimited hydropower for agriculture and industry.
- B769 MAKING OF A CHAMP (E 20: B)
Under private auspices, athletes representing 18 countries spend an 89-day training period in the United States to improve their skills in track and field sports.
- A134 MAKING OF A MURAL (M 10: C)
Thomas Hart Benton demonstrates essential steps in planning and completing a mural composition: methods of achieving three-dimensional effects and brilliant coloring.
- B135 MAKING OF FINE CHINA (M 20: C)
Manufacture of fine chinaware in America.

- B136 MALARIA ERADICATION (E M 15: B)
The story of the fight to eliminate malaria.
- C777 MAN AND RADIATION (E 30: C)
The story of man's uses of properly controlled radiation for the improvement of his everyday living.
- A137 MAN LEARNS TO FARM (E 10: C)
Man's development of improved farming methods from prehistoric times to the present. Shows through animation advances in agriculture, and resulting trade and cultural exchange among nations.
- B138 MAN LEARNS TO HEAL (E M 15: C)
The evolution of medicine from the time of the Pharaohs to the present.
- B448 MAN - MAKER OF ABUNDANCE (E M 21: B)
How machines have contributed to improved standards of living during the past century.
- B684 MAN OF PROGRESS: THE DE FOREST STORY (E M 15: C)
Highlights in the life of Dr. Lee De Forest, an inventor known as the "Father of Radio."
- B140 MAN OF THE LAND (E 20: C)
The story of oil and what it has done for the American farmer.
- C770 THE MARCH (E 30: B)
Documentation of events leading up to and including the August 28, 1963 Civil Rights March in Washington, D. C.
- C141 MARIAN ANDERSON (E M 25: B)
Vignettes of the singer's life with favorite solos.

- B442 MEAT WITH APPROVAL (E 20: B)
This film contains the story of the federal meat inspection program in the United States. Included in the film are the historical reasons of the program, how it is carried out, and what meat inspection assures the consumer.
- B142 MEDICINE (E M A 20: B)
This Atoms for Peace series film concentrates on atomic materials used in medical research and diagnosis. There is a sequence on a brain tumor patient, and sections on atomic materials being used in the treatment of hardening of the arteries, cancer, and hyperthyroidism.
- B832 MEETING IN SPACE (E M 15: C)
This film is a documentary of the successful flight of Gemini-7, December 4; the attempted launch of Gemini 6, December 13, 1965 and the successful flight of Gemini 6, 48 hours later as well as the rendezvous of the two spacecraft.
- B622 MEN AND BOATS (E M 18: B)
This picture is filmed in a fishing village on the east coast of Taiwan. About 600 boats sail daily out of the harbor. They provide much of the sea food for Free China.
- C680 MEN ENOUGH FOR THE JOB (E M 30: C)
4-H Club activities in a community.
- A815 MEN WHO CARE (E M 10: B)
The film shows the humane and social aspects of medicine in the United States.

- B147 MEN WHO GROW COTTON (E 20: C)
Shows how cotton was grown in plantation days and how it is grown today.
- C589 MIGHTY FINE UNION (E 32: B)
The story of the United Rubber Workers Union.
- B679 A MILE HIGH, A WORLD WIDE (E 20: C)
The Girl Scout Conclave of 1959, held in Colorado and attended by Senior Girl Scouts from 27 countries.
- B688 MILKFISH (M 20: B)
How to raise and propagate milkfish.
- C840 MORE INTERESTING PEOPLE (E 30: B)
Folk songs of the United States and several other countries.
- C717 MORE THAN MOUNTAINS—MORE THAN GOLD (E 30: C)
This film shows the scenic wonders of mountainous Colorado and also stresses the modern development of agriculture and industry in contrast to an early history of mining and cattle ranching.
- C746 MUSIC IN THE FOREST (E 26: B)
Story of a summer music camp for children at Interlochen, Michigan. Talented children are admitted on a competitive basis to study music, art, drama and the dance.
- D826 MY FRIEND THE ENEMY (E 34: B)
This film demonstrates that mutual cooperation between management and organized labor produces benefits for both groups.

- 5721P (A42)
A744 A NATION CHOOSES (E 10: B)
Ceremonies marking the entry of Jamaica into the British Commonwealth.
- C683 A NATION RISES (E M 26: B)
Film describes the rapid growth of the U. S. and the gigantic expansion of industry in the last half of the 19th Century and the early 20th Century.
- C151 A NATION SETS ITS COURSE (E M 30: B)
Difficulties experienced by the new nation of the United States in establishing a stable government are shown. The Constitutional Convention meets. After prolonged debate, a federal Constitution is agreed upon. Under President Thomas Jefferson's administration, the Louisiana purchase is negotiated. The Lewis and Clark expedition explores the vast new western territory. New national highways, the building of Erie Canal, the railroad and the steamboat accelerate the pace of internal trade.
- B451 THE NATIVITY (E 15: C)
A marionette show portraying the Christmas story.
- A153 NAUTILUS CROSSES THE TOP OF THE WORLD (E M 10: B)
The saga of the nuclear submarine Nautilus and its polar trip.
- D585 NEW AGE OF ARCHITECTURE (E 40: B)
Some of America's foremost architects discuss architecture and architectural problems.
- C583 NEW ENGLAND PORTRAIT (E 30: C)
An artist's tour of New England reveals the scenery,

sports, culture, industry and community life of the people of the northeast United states.

8776
B457 A NEW KIND OF SCHOOL (E 20: B)

The South Vietnamese government establishes vocational schools for refugees from communist North Vietnam.

3-10-110
4777-7
7A-12
1497
C157 NEW WORLD (E M 30: B)

Traces the discovery of America, early voyages by European explorers. Shows Indian life in eastern North America and the Indian civilization encountered by the Spanish; Spanish colonization, English free-booters on the Spanish Main, and the life of early settlers in New England and the South. Film closes with the growing conflict with the French and Indians as the new colonies expand westward.

B787 NEW YORK (E 15: C)

Panoramic view of New York City, including scenes of the skyline, skyscrapers, and the nightspots.

B159 NEW YORK WATER SUPPLY (M 20: C)

The system of storing, purifying, and transporting water to New York City.

8776
C813 NIGHT OF THE DRAGON (E M 26: C)

Utilizing actual battle scenes, this film presents a detailed illustration of South Vietnamese determination to remain free despite years of terrorist attacks by the Viet Cong. This film documents the communist origin of weapons of war, communist methods of infiltration and communist intimidation of the civilian population.

D004 1964 CONVENTIONS (E 40: B)

The stories of the Republican and Democratic conventions in 1964, during which Barry Goldwater and Lyndon Johnson were selected as the presidential candidates of their respective parties.

C458 NOT BY CHANCE (E M 30: C)

Describes the selection, training and professional development of teachers at American teachers colleges.

B617 NUCLEAR SHIP SAVANNAH (E M 20: C)

Film describes the Nuclear Ship Savannah and its construction. Explains its role in the construction of future nuclear-powered surface ships.

B715 NUTRITION (M 20: B) A lecture and demonstration on the importance of nutrition to man.

8776
B828 ONE SMALL CANDLE (E M 20: B)

This film shows resettlement of refugees from the Communist mainland in the U. S., South America, and England.

B461 THE OPEN ROAD (E M 20: B)

A bicycle association in America today has hotel accommodations. Students on trips pay nominal fees for board and lodging. This association serves to satisfy the thirst of the young to explore new places.

B467 ORIENTAL BRUSHWORK (E 20: C)

A presentation of an American artist's appreciation of oriental art. The relationship between painting and calligraphy is illustrated.

B466 ORIGINS OF THE MOTION PICTURE (E M 20: B)

Describes the origins and evolution of the motion

picture. Early motion pictures containing shots of historical significance are shown.

B849 THE OTHER WAR (E 15: B)

Shows the work of a South Vietnamese Reconstruction leader and his team in a village rebuilding homes, schools, roads and other community projects.

B748 OUR NEAREST STAR (E 12: C)

The first application of nuclear power in space. SNAP isotopic power system used in the Transit 4-A navigation satellite.

B220 OUR UNION AT WORK (E 20: B)

A film story describing the methods of organization and operation of the Textile Workers' union.

B692 PACIFIC VENTURE (E M 20: B)

Film shows how scientific research is improving living standards of isolated peoples of the Pacific.

A222 PAINTING AN ABSTRACTION (M 10: C)

Eliot O'Hara presents his technique of "abstracting" desired elements for watercolor painting.

B495 PAINTING CLOUDS (E 20: C)

O'Hara uses landscape paintings of various countries to explain the importance of clouds in pictures.

A496 PAINTING CROWDS OF PEOPLE (E 10: C)

O'Hara demonstrates how an artist may create impressions of crowds without defining individuals.

A223 PAINTINGS OF THE NEW WORLD (E 10: C)

Painting by American artists of the 19th century. A record of the country's growth.

C609 PARTNERS FOR PEACE (E 30: C)

東南了了

Presents the member nations of SEATO. Shows benefits to be derived from cooperation among free peoples of Southeast Asia. Emphasis is on economic and social development of area, with minor mention of military aspects of the organization.

B226 PATTERN FOR PEACE (E 20: B)

An exposition of the theme that the average American citizen has a deep and sincere desire for peace. At a town meeting a high school history professor outlines the U. S. Government's disarmament objectives.

B678 PEACE MAKER (E M 15: B)

In memory of Dag Hammarskjold, the late Secretary General of the United Nations, the film pays tribute to his efforts for peace.

C494 PEOPLE AND PETROLEUM (E M 27: B)

八木工

Story of Creole Petroleum Corporation's activities in Venezuela. Emphasizes economic, social benefits and an enlightened attitude toward foreign investment.

B229 PEOPLE OF THE WESTERN SHORE (E M 20: B)

A description of the geography, the people and industries of the American Pacific Coast.

B475 PEOPLE WIN THROUGH (E 20: B)

A presentation at the Pasadena Playhouse, California of the problems faced by a nation new to the ways of democracy -- Burma.

B728 PERSONAL REPORT #2 (E 15: B)

A description of the American concept of mass education and specifically activities at the Calvin Coolidge School, Washington, D. C.

C230 PETRIFIED RIVER (E M 30: C)

The story of uranium: describes the geological process by which uranium deposits were formed and for millions of years remained buried in the canyon walls of the Colorado Plateau; the present day uranium search, the uranium mining industry and some of the uses of radioisotopes.

B231 PHILIPPINE PROGRESS (E M A 20: B)

Deals with the repair of World War II damage and the economic and social progress of young Republic of the Philippines since independence on July 4, 1946. Gives historical information and explains the role of the United States in relation to the Philippines.

C233 THE PHOTOGRAPHER (E 30: B)

Cultural and artistic values associated with photography revealed in the life and work of Edward Weston.

C234 PILGRIMAGE OF LIBERTY (E M 30: C)

A presentation of American monuments, memorials, national parks and historical landmarks and their significance to the people of the United States. Included are Mt. Vernon, Monticello, the Hermitage and the birthplace of Lincoln; also Yosemite and Yellowstone National Parks and other points of interest in the United States.

A618 PIONEER IN INTER-PLANETARY SPACE (E 10: B)

Covers launching of an American space probe. Discusses scientific importance of project and information expected to be developed from signals being received from the probe's instruments.

C478 A PLACE IN THE SUN (E 25: C)

In special public schools the State of California educates children afflicted with cerebral palsy. Cerebral palsy defined and modern treatment illustrated.

B235 PLANNING FOR PLENTY (E 20: B)

Depicts India's effort to build a larger food supply.

C480 PLAY CHAMPIONSHIP BASKETBALL (E 60: B)

Series of six integrated films on (1) Individual Offense; (2) Individual Defense; (3) Team styles of Play; (4) Offensive Plays and Variations; (5) Defense Styles; (6) Drills. Demonstrations explain shooting, passing, dribbling, tapping, blocking, use of arms and hands, defense on jump, guarding shooter, infractions, types of plays and major phases of court play. Promotes spectator understanding.

B481 PLAY VOLLEYBALL (E 20: B)

The game of volleyball and how it should be played.

B572 PORTRAIT OF A CITY (E M 17: C)

The story of Detroit, Michigan, from its founding in 1701; cultural and industrial development of the city. Transition from horse and buggy to automobile; main street, by-ways and slums, waterfront, suburbs, recreation areas.

A238 POULTRY RAISING (E A 10: B)

Raising White Leghorn and Plymouth Rock chickens.

B239 POWER AND THE LAND (E M 20: B)

The role of electricity in improving the rural standard of living.

- C766 POWER FOR CONTINENT SEVEN (E M 30: C)
The creation of the nuclear-power town, McMurdo, in Antarctica-Continent Seven. Installation of the nuclear power plant.
- A619 POWER TILLER (M A 10: B)
An exhibition and demonstration of mechanized tillers sponsored by the Taiwan Provincial Farmers' Association.
- B768 THE PRESIDENT (E M 15: C)
The film shows the transfer of the power of the presidency upon the death of President Kennedy. President Johnson is shown as he takes over control of the administrative section of the American federal government.
- B803 THE PRESIDENT AND THE PRESS (E M 15: C)
Shows President Johnson's contact with the people through formal and informal news conferences, and other public events such as the signing of the Civil Rights Bill.
- B838 PRESIDENT'S COUNTRY (E 23: C)
An Agency-produced documentary on the hill country of central Texas in the American southwest. The film relates the land and its people to the mainstream of America through one of the hill country's products, Lyndon Baines Johnson, 36th President of the United States.
- B487 PRINCIPLES OF ELECTRICITY (M 20: C)
Animation is used to explain principles of electricity: atomic structure of matter, action of electrons within

atom. Volt, ampere, ohm defined. Units of pressure, electric current and resistance established as principles in flow of electricity. Magnetism, magnetic fields; conductors, non-conductors. How magnetic fields function in generation and application of electricity.

- B660 PRINTMAKERS (E M 20: C)
Demonstrates the creative abilities of outstanding American graphic artists and describes the technical skills of each in his individual approach to the art of printmaking.
- A244 PROBLEMS OF A SMALL TOWN (E M 10: B)
Democratic processes by which a small New York State community solves civic problems; explains work of a city council.
- C756 PROFILE - GORDON COOPER (E 30: B)
This is the story of astronaut Cooper's life from boyhood in Shawnee, Oklahoma up to but not including his August 1965 space flight.
- A786 PROFILE OF POWER (E M 10: C)
This film shows the Seventh Fleet supporting US commitments to the free nations of Asia.
- B804 PROJECT APOLLO-MANNED FLIGHT TO THE MOON (E M 13: C)
Describes the expected performance of the three-crew-member team on the proposed trip to the moon.
- B819 PROJECT GEMINI: MISSION CONCEPT (E 20: C)
Utilizing animation and technical narration, describes research and planning necessary to the development and execution of the first phase of the Gemini Prog-

ram. In an effort to determine man's capabilities during an extended orbit necessary for a successful moon landing, anticipated problems facing astronauts on such a mission are researched and described in this film.

C712 PROJECT HOPE (E 30: C)

The Indonesian Assignment of the S. S. Hope, the floating medical center, sponsored by the People to People Health Foundation. The facilities of the ship and the activities of the doctors and nurses in fighting disease and in training other doctors and nurses are described. The humanitarian aspects of the mission are shown.

B763 PROJECT TELSTAR (E M 18: C)

Description of successful launching and operation of Telstar, a joint communications project by private enterprise and government. First telephone conversation relayed through the satellite.

A627 PROPAGATION OF CARP (A 10: B)

How to raise carp successfully on Taiwan.

B661 PROSPECTUS FOR GROWTH (E M 20: B)

The film shows how the investment of foreign capital contributes to the economic development of communities and nations, and to the standard of living of the people. Capital investment from the United States has made possible on a vast and rapid scale improvements in Latin America, the Near East and Far East.

D489 PUBLIC HEALTH NURSE (M 30: C)

The many duties of a small town public health nurse.

B797 QUEST FOR FREEDOM (E 15: C)

The story of efforts to secure political and individual freedom, from pre-history to the American Declaration of Independence.

C506 RAINBOW VALLEY (E 30: C)

The story of conservation of soil, water resources, plant and wildlife in United States National Parks.

B248 RECITAL NO. 1 (E 20: B)

Performances by musical artists: (1) Artur Rubinstein-Chopin's "C Sharp Minor Scherzo" (2) Marian Anderson - "Oh, What a Beautiful City" and "He's Got the Whole World in his Hands." (3) Adres Segovia-"Theme and Variations" by Sor. (4) Jan Peerce-Leoncavallo's "Mattinata." (5) Jascha Heifetz - Weinawski's "Polonaise in D Major."

B249 RECITAL NO. 2 (E 20: B)

Performances by musical artists: (1) Segovia-Torroda's "Sonata." (2) Marian Anderson - Handel's "Berrusung." (3) Rubinsten-Chopin's "Polonaise in A Major." (4) Heifetz - Paganini's "Caprice No. 24."

A502 REHABILITATION OF THE BLIND (M 10: B)

Industrial Home for the Blind, New York. Reeducation of blind to overcome disability and lead independent lives; readjustment of attitude, physical training, aptitude testing and industrial training, developing new skills.

B737 REHEARSAL FOR TOMORROW (E M 25: B)

Story of the Eastman School of Music, Rochester, New York. Performances by Eastman String Quartet and the school's symphony orchestra.

B507 REUNION BRIDGE (M A 20: B)

Depicts importance of irrigation for farming with particular emphasis on the "Rotational Irrigation" system which is most appropriate for Taiwan farms.

C844 The ROAD AHEAD (E 30: B)

A dramatic documentary illustrating the problems faced by 2 young friends, a Negro and a Caucasian. The Negro, a high school graduate, obtains a position with "in-service" training toward advancement. His white friend, a high-school "drop out" only finds unskilled work. The Negro helps his friend to identify his problem and persuades him to begin night school classes toward his high school diploma.

C252 ROAD OF A HUNDRED DAYS (E M A 30: B)

A Greek production depicting people of a small mountain village working together to build a road to escape isolation from the outside world. It must be completed in 100 days for the celebration of their Saint's feast day. Unexpected and welcome assistance comes from America.

C686 ROBERT FROST (E 30: C)

Selected poems of Robert Frost inspired by the New England countryside are recited by the late philosopher-poet. The film depicts his contribution to the American cultural scene as a teacher as well as a poet and philosopher.

A620 RODENT CONTROL (M A 10: B)

Farmers in Taiwan join a campaign sponsored by the JCRR to eradicate some 40-million rats roaming the farmland.

A251 R. F. D. (RURAL FREE DELIVERY) (M 10: B)

Shows the rural mail delivery system which provides U. S. country people, at no additional cost, with the same postal service that is enjoyed in the cities.

C253 ARTUR RUBENSTEIN, NO. 101 (E M 25: B)

See page 52 for numbers performed.

C254 ARTUR RUBINSTEIN, NO. 102 (E 25: B)

The artist in his drawing room performs a concert of Chopin selections including: "Waltz in C Sharp Minor." "Scherzo in C Sharp," "Nocturne in Sharp," "Polonaise in A Sharp" and "Mazurka in C Sharp Minor."

C648 ST. LAWRENCE POWER PROJECT (E M 30: C)

The story of the construction of the St. Lawrence power project between the United States and Canada.

A783 SATURN SPACE VEHICLE (E M 10: C)

Describes basic technological and scientific research involved in designing, building and launching the world's largest rocket.

A774 SCHOOL FOR STRINGS (E M 10: B)

String musicians at work in a unique school for instrumentalists.

B258 SCHOOL IN CENTERVILLE (E 20: B)

The seventh grade is used to illustrate a good teaching program. Guided by the teacher, the pupils map out topics of study about their town and investigate each one.

A759 SCHOOL AT RINCON SANTO (E 10: B)

The people of the village of Rincon Santo, with technical assistance provided by the Government of Colombia, join in the spirit of the "Alliance for Progress" and construct their own schoolhouse.

B525 SCIENTIFIC ADVANCEMENT (E M A 20: B)

Production of atomic electric power; use of atomic irrigation to increase production by food plants and to preserve food; use of isotopes to insure precision thickness control in manufacturing and to measure soil density in road building; treatment of cancer and heart disease and in the study of photo-synthesis.

C681 SCOUT TRAIL (E M 30: C)

Activities of Cub Scouts, Boy Scouts and Eagle Scouts in the United States.

A260 THE SCROLL (E M 10: C)

Based on Chinese-American artist Dong Kingman's unique "Report to the State Department" on his world tour in 1954 as a participant in a cultural exchange program. Paintings and drawings sketched on tour depict the artist's impressions of countries visited.

A508 SEA LIONS BASEBALL TEAM (E M 10: B)

Story of small boy considered too young to play baseball with older companions. On visit to the zoo, he becomes interested in how seals catch food as it is thrown to them by the keeper. After much hard work and practicing, he is able to throw food to the seals correctly. With his newly acquired technique, young boy is accepted as a member of the baseball team.

C024 SECOND ASIAN GAMES (E M 30: B)

7.11.54 The complete story of the Second Asian Games held in Manila in 1954. Teams of many Asian countries are shown in action.

C528 SHARE IN TOMORROW (E M 30: B)

The history and operation of the New York Stock Exchange, its role in the industrial growth of the United States and its function in the American economic system.

B801 SHIELD OF PROGRESS (E M 20: B)

東南アジア A description of communist aggression in Southeast Asia and the birth of SEATO.

B510 SHOOT THE NET (E 20: B)

Stresses the cooperation at sea among fishermen of several nations, and shows a Dutch trawler on its annual voyage to the Dogger Bank.

D263 SHRIMP FISHERMAN (E M A 60: B)

X7.3.7 Methods and problems of shrimp fishing in the Gulf of Mexico. Shown are operations of ocean-going commer-

cial trawlers and small independent operators and Louisiana family and town life.

C833 SINEWS OF FREEDOM (E M 30: C)

中国
Film shows the strides the Republic of China has made in developing a healthy economy. Agricultural and industrial progress are featured and the role of U. S. aid is explained.

A665 THE SINK (M 10: B)

How to build and maintain economical and sanitary sinks in a farm house.

C264 SKIPPY AND THE THREE R'S (E M 29: C)

First grade children learn reading, writing and arithmetic; demonstrated in the story of a small boy who wanted and got a bicycle (modern teaching methods at work).

A511 SOFTBALL FOR BOYS (E 10: B)

Pitching, catching, fielding, batting techniques, catcher and pitcher team-work, analyzed in slow motion and in game situations.

B677 SEATO SAFEGUARD FOR FREEDOM (E M 20: B)

71
A film on the SEATO Foreign Ministers Conference held in Bangkok in March 1961 and on the meetings of SEATO Military Advisors.

A702 SPOTLIGHT ON VIETNAM (E 10: B)

71
Shows efforts to rebuild the country in spite of Communist efforts to destroy and disrupt South Vietnam.

B269 THE STATES AND THE NATION (E M 20: B)

Describes relationship among American states and the federal government. Outlines rights and duties reserved

to states and explains the responsibilities of state governments including inter-relationships and specific powers under the Constitution.

B637 STEELWORKERS' UNIVERSITY INSTITUTE (E 20: B)

71
Educational program sponsored by the United Steel Workers on university campuses in the United States and Canada.

C843 STILL MORE INTERESTING PEOPLE (E 30: B)

Folk songs of the United States and several other countries.

B270 STOREHOUSE OF HISTORY-NATIONAL ARCHIVES (E M 20: C)

A visit to the United States National Archives. Describes methods devised for the care and preservation of historical documents and government records. Shows efficiency with which archives serve national interests and research.

B521 STORY OF A TOWN (E 12: B)

71
A small town in the Philippines needs a road which will connect it with surrounding villages. The men and women of the village gave their labor, but the task was too difficult without mechanical assistance. The town council takes action. Funds are raised to pay for the rent of a bulldozer with help from FOA. A help-to-self-help documentary.

C765 STORY OF CAMP CENTURY (E M 30: C)

71
Construction of Camp Century, a nuclear-powered U.S. Army arctic research laboratory under the Greenland ice cap.

A516 STORY OF DOCTOR JENNER (E 10: B)

Story of the discovery of small-pox vaccination.

B271 STORY OF KOULA (E 20: B)

Economic aids extended to farmers in Greece by the American Government under the Marshall Plan, and outdoor scenes of Greece.

B714 STORY OF LI LI CHU (E M 20: B)

Rural development and economic progress in Taiwan as seen through the eyes of a young Chinese woman.

B523 STORY OF THE NATIONAL LABOR RELATIONS BOARD (E 20: B)

Shows workers in a non-union plant forming a union and through collective bargaining obtaining employee benefits. Depicts the role of the National Labor Relations Board in settling labor disputes.

C584 STORY OF 32 B (E M 30: B)

Depicts the various types of work performed by members of Local 32 B, and describes the functions of the Building Service Employees International Union.

A664 STOVE AND WHITE WASH (M 10: B)

Film demonstrating a simple method of improving the efficiency of the stoves used in the Taiwanese farm houses, and how to clean and whitewash a house.

A776 STUDENT ENGINEER (E M 10: B)

A young American student engineer combines studies and work.

A799 STUDENT TEACHER (E 10: B)

The experiences of a senior university student while working part-time, attending class and participating in

a student-teacher program.

B518 SULPHUR (E 20: B)

A technical film on the mining and industrial use of sulphur.

B649 SURVEY OF ASTRONAUTICS (E M 20: C)

Report on the Government's research rocket program and a theoretical forecast for development Problems inherent in manned satellite operations are discussed.

C274 SYMPHONY ACROSS THE LAND (E M 50: B)

Some leading U. S. symphony orchestras and the role they play in the cultural life of the United States.

D275 SYMPHONY OF THE AIR (E M 40: B)

Covers a tour of Japan by the Symphony of the Air Selections included in film are the overture from "The Roman Carnival," Opus No. 6 by Berkioz: the first movement of Mozart's "Symphony No. 35 in D Major," known as the "Haffner," the "Waltz of the Flowers," from Tschaikovsky's "Nutcracker Suite;" the "Polovetsian Dances," from "Prince Igor," by Borodin, and the fourth movement of Beethoven's "5th Symphony, Opus No. 67 in C Minor."

C735 SYMPHONY ROAD (E M 30: B)

The story of the Boston Symphony Orchestra -- its history, the varied national origins of members of the orchestra, the broad social scale of of audiences, and a brief historical presentation of Boston--the home of the first symphony orchestra in the United States.

B778 SYNCOM (E 12: C)

Animated description of the launching and operation of the world's first synchronous robot communications satellite.

B546 TAILGATE MAN FROM NEW ORLEANS (E 20: B)

Gives brief background on jazz exponent Kid Ory, and origins of jazz in New Orleans. Ory's Creole Band plays several jazz classics.

B278 TANGLEWOOD MUSIC SCHOOL (M 20: B)

An introduction to the music school at Tanglewood, Massachusetts, including orchestra rehearsal, school life and a summer performance by Serge Koussevitsky.

B659 THE TASK BEGUN (E M 20: C)

27-7
A-2413
17-92
Covers the late President Kennedy's visit to Paris, Vienna and London and includes major policy pronouncements and public statements made by the President in the course of his journey and in his report to America upon his return.

B723 TEACHING ENGLISH CONVERSATION (E 17: B)

This film gives a demonstration and explanation of the informant-drill technique for teaching conversational English.

B632 TEACHING ENGLISH GRAMMAR (E 20: B)

A demonstration and explanation of the informant-drill technique for teaching English grammar.

B545 TEACHING ENGLISH NATURALLY (E 17: B)

This picture gives an explanation of the informant-

drill technique for teaching conversational English.

B851 TEACHING ENGLISH PRONUNCIATION (E 18: B)

Shows the the techniques of teaching English pronunciation.

A091 ALTHEA GIBSON - TENNIS CHAMPION
(E M A 10: B)

Highlights of the career of Althea Gibson, leading US female tennis player and winner of the U. S. Womens Singles Championship at Forest Hills, 1957.

C300 T. V. A. (E M 30: B)

The reawakening of a land and its people to new life, new industries and prosperity, after of decades poverty and despair, are depicted in this film. This was made possible through the hydroelectric project known as the Tennessee Valley Authority.

C700 TENTH PACIFIC SCIENCE CONGRESS (E M 30: C)

Describes the Hawaiian setting of the Congress and some of the problems common to the Pacific area which are the subject of extensive research and discussion at the international level. Field trips reveal the unusual beauty of the island.

A529 THAILAND - LAND OF ATHLETES (E 10: B)

41
The Physical Education Teachers College in Bangkok where students from all of Thailand go to learn about sports that they, in turn, may teach.

C281 THAT WE MAY BETTER SERVE (E 30: B)

2176
Portrays life of a medical student and an agricultural student in the Philippines. Their ambitions, successes, failures and how their lives in the province have been

- affected by Huk raids and propaganda. How Huk raids wreak havoc with the lives of people in the province.
- B001 THEODORE ROOSEVELT, AMERICAN (E 20: B)
The life and times of American President Theodore Roosevelt.
- A671 THEY ARE NOT ALONE (E M 10: B)
Film covers the visit to Berlin of then Vice President Johnson which coincides with arrival of 1500 additional American troops.
- B282 THEY NEED NOT DIE (M A 20: B)
Explains the work which is being done by Government of India in cooperation with WHO, TCA, and the United States under the Indian Government's Five Year Plan to promote better health and sanitation measures, as a means of lowering the infant death rate.
- C348 THIS IS AUTOMATION (E M 30: B)
An analysis of automation criteria for determining what industrial operations can best be performed by automation.
- B283 THIS IS MY PHILIPPINES (E M 20: B)
An informal history of the Philippines, the film covers ethnic and cultural backgrounds, geography, economic and political development.
- B547 THIS IS QUEMOY (E M 15: B)
Shows the calmness of people on Kinmen (Quemoy) during and after the Communist bombardment in August 1958. Shows the people rebuilding their villages damaged by the shelling.
- A773 THIS LAND (E M 10: B)

A conservationist spends a week with elementary school children at a mountain camp teaching them to appreciate nature.

C285 THREE OF OUR CHILDREN (E 30: B)

Narrated by James Mason, the film explains types of medical aid provided for children by UNICEF in different world areas. The case histories covered are a little girl in Greece, the young son of a chieftain in French Equatorial Africa and a young pregnant woman in the Philippines.

B741 THREE THOUSAND YEARS OF CHINESE ART (E M 20: C)

A chronology on film of three thousand years of Chinese art through photography of treasures in the Palace Museum in Taipei.

A689 THUNDER TIGER TEAM (M 8: B)

The Chinese Air Force Thunder Tiger Team visited Viet-nam in 1961. A formation of nine Chinese jet fighter planes demonstrated impressive skill in front of a large group of Vietnamese onlookers.

B542 TICKET TO MANILA (E M A 20: B)

Feature-type story depicting Philippines economic and social progress as an independent Republic. Story told through experiences of a Filipino farmer on a trip from Barrio to Manila for son's graduation. Enroute the farmer sees many reconstruction projects, and agricultural improve ments that the country has accomplished during the past decade.

B543 TILAPIA (E M A 15: B)

アトク

Shows how to raise Tilapia in Vietnam. This program helps the citizens supplement their diet and increase their income.

B286 TIME (M 20: B)

Story of the invention of clocks and watches.

B847 TO BEGIN AGAIN (E 17: C)

キューバ

Story of Cubans leaving their homes for the United States since 1965 under the permission of the Cuban government on the condition that each one can only take a suit and a bag with him.

C289 TO FREEDOM (E M 30: B)

フレンチ
インド

An episode of the French and Indian War is shown against the political background of the struggle. The colonies grow restive under restrictions and taxation. Armed clashes are followed by the Declaration of Independence. Washington's army is seen in principal campaigns. The colonies win their freedom.

B290 TO GREATER VISION (M 20: B)

Illustrates the manufacture of optical glass for spectacles, binoculars, microscopes, etc.; also their principles.

B782 TO KEEP THE PEACE (E M 18: C)

Film shows how American military might, on land, sea, and in the air, is dedicated to keeping the peace.

C293 ARTURO TOSCANINI (E M 30: B)

Arturo Toscanini conducts the NBC Symphony Orchestra with Jan Peerce, soloist, and the Westminster Choir, in a special program recognizing Italy's liberation from Fascist oppression, featuring overture to Giuseppe Verdi's "The Force of Destiny" and "Hymn of the Nations."

A630 TO THOSE WHO CHOOSE FREEDOM (E 10: B)

アトク

Story behind the mass evacuation of North Vietnam, of the people who left behind their homes and shops to seek refuge in the central and southern sections, and of the cooperation of the Free World in the safe transportation of these refugees.

B288 TODAY'S CHICKS (E 20: C)

American chickens are produced by a highly specialized industry of more than 9,000 commercial hatcheries. Many of these hatcheries operate under the National Poultry Improvement Plan. Scenes cover the basic operations of this program including selecting breeders, methods of testing them for pullorum disease, sanitation procedures in the hatchery and in the field, and the production of pedigreed breeding stock.

C292 TOM SCHULAR, COBBLER-STATESMAN (E M 30: C)

This animated cartoon is a lively and simplified explanation of American history in the Revolutionary War period. The film emphasizes the contribution of the individual to a democratic society.

C825 TOMORROW IN THEIR HANDS (E M 30: C)

エルサルバドル
ボリビア
インド
パキスタン
タイ
エチオピア

This documentary film describes some of the uses of nonmilitary aid to developing nations. Aid projects in El Salvador, Bolivia, India, Pakistan, Thailand and Ethiopia are depicted.

C713 A TOUR OF THE WHITE HOUSE WITH MRS. J. KENNEDY (E 60: B)

A tour of the White House, conducted by Mrs. John F. Kennedy.

C613 TOWARD TOMORROW (E M 30: B)

The life of Dr. Ralph J. Bunche. Highlights of early youth, depicting the influential role of his grandmother in encouraging continuance his education; reviews Bunche's student life, and accomplishments as a distinguished American statesman, Nobel Prize winner. Emphasizes American recognition of individual ability and freedom of opportunity.

B697 TOWER OF LEARNING (E M 20: C)

Describes how ethnic groups in Pittsburgh, Pa., worked together to create the 18 Nationality Rooms in the University of Pittsburgh's Tower of Learning. This monument to the cultures of 18 nationalities also serves as a symbol of the university's broad program of international cultural and educational exchange.

B296 TRAINING MEN FOR THE ATOMIC AGE (E M 20: B)

Documents the training program in nuclear physics of foreign scientists sponsored by the U.S. Atomic Energy Commission. Covers activities at the University of North Carolina, University of Pennsylvania, Oak Ridge Institute of Nuclear Studies and International School of Nuclear Science and Engineering at La Grange, Illinois (a part of the Argonne National Laboratory) and construction of the nuclear reactor at Shippingport, Pa.

A297 TRANSATLANTIC (E 10: C)

Color cartoons depict the discovery of the New World, European migration, and the subsequent independence

of the United States. Shows how technological progress in transport and communications brings people closer economically, socially, and culturally.

B839 TRANSPORTATION USA (Music 21: C)

A colorful overview of transportation systems in the United States showing how modern technology has helped to integrate these networks, expediting the movement of people and materials throughout the country. Covers air, water, rail, and highway systems serving a variety of geographic areas as well as views of dogsleds, cable cars, and space rockets.

C538 TREES TO TRADE (E 30: C)

The usefulness of wood in building houses. Describes how wood is processed, designed and made into household necessities.

B780 TROUBLED HARVEST (E M A 13: B)

The story of the emergence of the new state of South Vietnam, its trials and stresses, and its hope for the future.

A539 TUBERCULOSIS (E M 10: C)

The nature, diagnosis, treatment of pulmonary tuberculosis; processes of infection and reinfection explained; preventive measures and curative treatment stressed.

A707 TUTANKHAMEN'S TREASURES (E 10: C)

The opening by Mrs. John F. Kennedy of an exhibit of Egyptian King Tutankhamun's treasures at the National Gallery of Art in Washington, D.C.

A629 UNHAPPY ISLAND (E M 10: B)

Excerpts from President Kennedy's address before the

American Society of Newspaper Editors in which he discusses the Cuban situation, warns of the danger of Communism to nations of the Hemisphere, and commits the U.S. to an active defense of freedom. The film includes areas of conflict in Cuba, in Hungary and in the Far East as Mr. Kennedy contrasts communist promises with deeds.

A303 UNIONISM ARRIVES IN HONDURAS (E 10: B)

ホンジュラス
As the basis for Honduras national economy, the export of bananas is vital to the whole country. In 1951, seeking a better standard of living, the banana workers went on strike. Refusing blandishments of communist infiltration groups, the workers and employers negotiated a settlement and their first labor union was formed.

C762 UNITED IN PROGRESS (E 30: C)

Covers President Kennedy's meeting with the presidents of Central America and Panama at San Jose, Costa Rica in March 1963.

B305 THE UNITED STATES TODAY (E M A 20: B)

The film attempts to explain American character and aspirations, emphasizing dedication to principles, intellectual and spiritual freedom and the worth of the individual. Shows U.S. military and industrial capacity, agricultural and scientific potential.

B307 U. S. A. (E M A 40: C)

Tour of the United States, interspersing American history and geography with scenes of American people at work, at play. Grand Canyon, New England and

Great Lakes area, Midwest, Rocky Mountains, Southwest and South. Describes characteristics of each locality.

A308 U.S. LABOR UNITES (E 10: B)

A filmed report on the merger convention in New York City in December 1955 in which the American Federation of Labor and the Congress of Industrial Organizations united under President George Meany following a 20-year split. Focuses on labor leaders from many parts of the world who attended the event as guests of American labor. Stresses the significance of the new unity to United States workers in all trades and crafts.

B791 VALLEY REVISITED (E 16: B)

The film shows the development of the Tennessee Valley Authority and how the T.V.A. has benefitted America. Historical film clips are included.

B314 VERSATILE SOYBEAN (M 20: B)

The film depicts the many uses of the common soybean in industry, medicine, and other parts of modern life.

C841 VIETNAM; THE OTHER WAR (E 60: C)

アメリカ
Focuses on Binh Dinh province of South Vietnam, detailing in microcosm the scope of the 1966 joint US-South Vietnamese rural construction and development activities underway in South Vietnam.

A317 THE VILLAGE AND THE SCHOOL (M A 10: C)

An animated cartoon designed for rural audiences. A graphic presentation of the value of education and its contribution to the well-being of mankind. Education

brings benefits to the individual, the family and the village by raising the standard of living and increasing knowledge of the outside world. Emphasizes the importance of literacy to children.

A318 THE VILLAGE AND THE TECHNICIAN (M A 10: C)

An animated cartoon designed especially for village audiences, this film demonstrates the advantages of adopting new agricultural methods. An agricultural agent describes his problems in persuading villagers to try new farming practices. He finally shows them a film portraying a similar situation in the U.S. where problems of erosion and poor soil were solved when farmers used new and better methods. Understanding brings about a change in attitude and results in a bumper crop.

C835 VISIT TO WASHINGTON WITH MRS. LBJ (E 60: C)

Shows Washington today and traces its historical development. The film is in behalf of a more beautiful America, and shows scenes which range from the landscaping of the White House to slum clearance.

A807 WALK IN SPACE (E M 10: B)

Shows the space journey of James McDivitt and Edward White in Gemini 4, during which Astronaut White spent 20 minutes outside the spacecraft.

A554 WATER; FRIEND OR ENEMY? (M 10: C)

Water can be polluted by human waste, and that can cause sickness. Easy-to-understand protective measures can prevent pollution of wells and springs. Water may also be purified by boiling.

B608 THE WAY AHEAD (E M 15: B)

The presentation of a new method of teaching high school physics developed by the Physical Science Study Committee at the Massachusetts Institute of Technology for use in American schools.

C555 WAYS OF A FIELD CHAMPION (E M 30: C)

Retriever dogs are hunter's best friends. Half the success of hunting is in the retrieving of game. English setters, terriers, and cocker spaniels are some of dogs trained for hunting. Obeying commands and recognizing hand signals are some lessons retriever dogs must learn.

B321 WE BUILD A TOWN (E 15: B)

A story of India's refugees uprooted from their homes and how, with their hands and the help of their government, they build a new life. Working together they build a town for fifty thousand people, transforming barren land into a thriving community.

A788 WE SHALL OVERCOME (E M 10: B)

Covers highlights of a Presidential address to Congress calling for action on voting rights.

B830 WEALTH OF A NATION (E 20: B)

Illustrates that individual expressions of freedom of action and thought in all areas of life-social, economic and political-are evidence of the strength and progress of a nation.

C322 WELCOME TO WASHINGTON (E M 30: C)

Shows Washington as an international capital and a brief history of the city. Describes structure of three

main branches of the U.S. Government: legislative, executive, judicial, against visuals of buildings in Washington. Takes viewers to popular tourist points of interest.

- C 324 WESTERN SYMPHONY (E 30: C)
Performance by the New York Ballet based on Western American folk themes.
- B 325 WHAT A LAND TENANT SHOULD KNOW (E 20: B)
The land tenant system is explained. A pictorial description and explanation of the new land reform system governing the relationship of land owner to his tenant farmer.
- B 558 WHEN THE COMMUNISTS CAME (M A 20: C)
In cartoon form. a village school teacher and his family life on the China mainland and what happened to them when Communists came.
- B 675 WHITE HOUSE PAST AND PRESENT (E M 15: C)
A description of the White House as originally designed and built and of the present structure built after the War of 1812 with its subsequent series of modifications and additions. The presentation of both exteriors and interiors shows the evolution of the Executive Mansion through 1960 and newsreel clips of former residents provide an historical perspective.
- A 655 WILMA RUDOLPH - OLYMPIC STAR (E M 10: B)
Wilma Rudolph, track star and winner of three Olympic Gold Medals, is shown in competition at the 1960 Rome Olympics and upon return to her home in Nashville, Tennessee where ceremonies are held in

her honor. Sequences cover life with her family, her college activities and friends, and U.S. track meets in which she participates.

- A 561 WINGED SCOURGE (M 10: B)
The physical and economic effects of malaria, its cause, protection against the disease, and effective medical treatment.
- B 635 WINTERTHUR - AN ADVENTURE IN THE PAST (E 20: C)
Filming of the Du Pont collection of American antiques of the 17th, 18th and early 19th centuries housed in a museum near Wilmington, Delaware.
- C 672 WITH HAND AND HEART (E M A 30: B)
The story of a Korean amputee's rehabilitation at the Amputee Center in Taejon and at the Rural Institute which provides training for rural leaders. Shows work of American Church World Service and the Union Christian Service Centers.
- C 740 WITH MUSIC RING (E M 30: C)
A presentation of the Mormon Tabernacle of Salt Lake City, Utah.
- B 331 WONDER HOUSE (E 20: B)
The film depicts the inner workings of one of the world's most famous museums, the American Museum of Natural History in New York.
- C 328 WOODROW WILSON-SPOKESMAN FOR TOMORROW (E M 30: B)
Deals with the works and aspirations of Woodrow Wilson as President of the United States. Relates his



efforts for peace, hatred for war and his crusade for the League of Nations.

B335 WORKING TOGETHER (E M 20: B)

The story of regional and international cooperation of scientists and governments in the development of peaceful uses of atomic energy.

A628 THE WORLD WATCHES AN EXPERIMENT IN SPACE (E M 10: B)

Shows the flight into space from Cape Kennedy by Astionaut Alan Shepard. Film covers the foreign and American news corps and cameramen who are given full information on the preparations and scientific goals of the first U.S. manned space flight.

C800 TO THE FAIR (E 28: C)

Introduction to what was seen at the 1964 New York World's Fair with exhibits from 40 nations and 50 American states.

B781 WORLD'S FAIR - NEW YORK (E M 18: C)

Views of the now-concluded World's Fair in New York. The film shows exhibits of 80 nations and their products.

C643 THE WU FAMILY (E M 30: C)

中国
The tragic story of the breakup of a Chinese farm family on the mainland under the impact of the Communists and their attempt to poison the mind of a student son.

C650 X - 15 (E M 30: C)

Development and testing of the X-15, the U.S. combined airplane and space vehicle.

C805 YANKEE PAINTER (E M 30: C)

A record of the works of the 19th century American artist, Winslow Homer.

C785 YEARS OF LIGHTNING, DAY OF DRUMS (E 90: C)

The picture views six major programs inaugurated and pursued by President Kennedy during his occupancy of the White House. These are the Alliance for Progress, The Peace Corps, Exploration of Space, Civil Rights, Pursuit of Peace and Military Preparedness. These, in turn, are projected against the background of his funeral ceremonies and the assumption of the Presidency by Lyndon B. Johnson. (Showing by special arrangement only.)

B337 YELLOWSTONE NATIONAL PARK (M 20: C)

Scenic views of one of America's most famous National Parks.

D339 THE YUKAWA STORY (E M A 40: B)

日本
Story of a Japanese scientist who was invited to the United States to work in the Institute for Advanced Studies where many scientists come from far places to think and discuss their work.